

CMB ANISOTROPIES: CURRENT STATUS & PERSPECTIVES

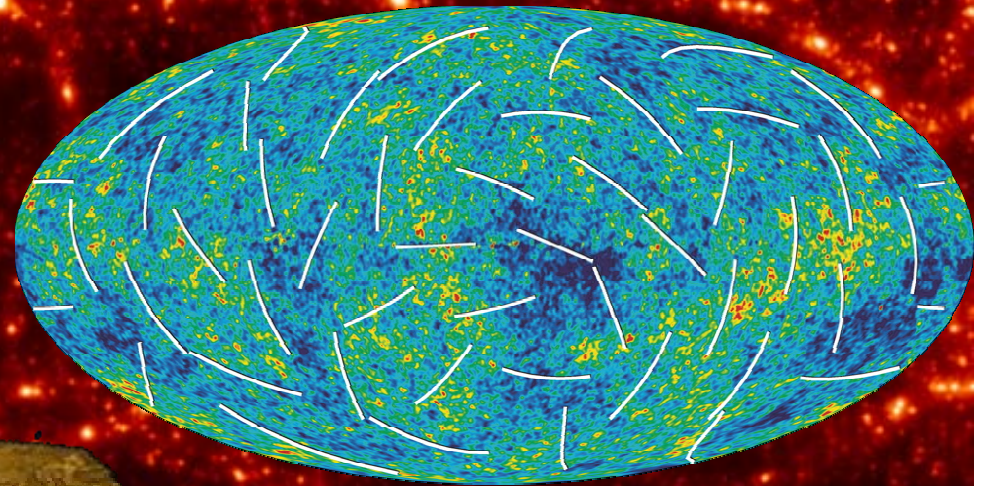
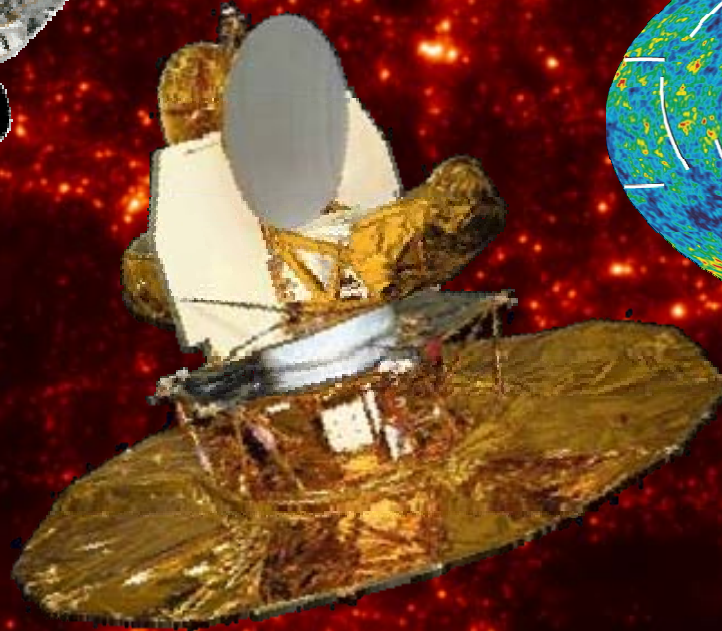
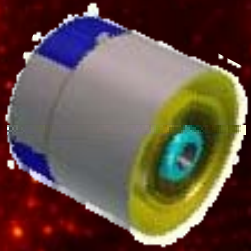

F. R. BOUCHET

INSTITUT D'ASTROPHYSIQUE DE PARIS, CNRS

IAP, PARIS, MAY 5TH 2006

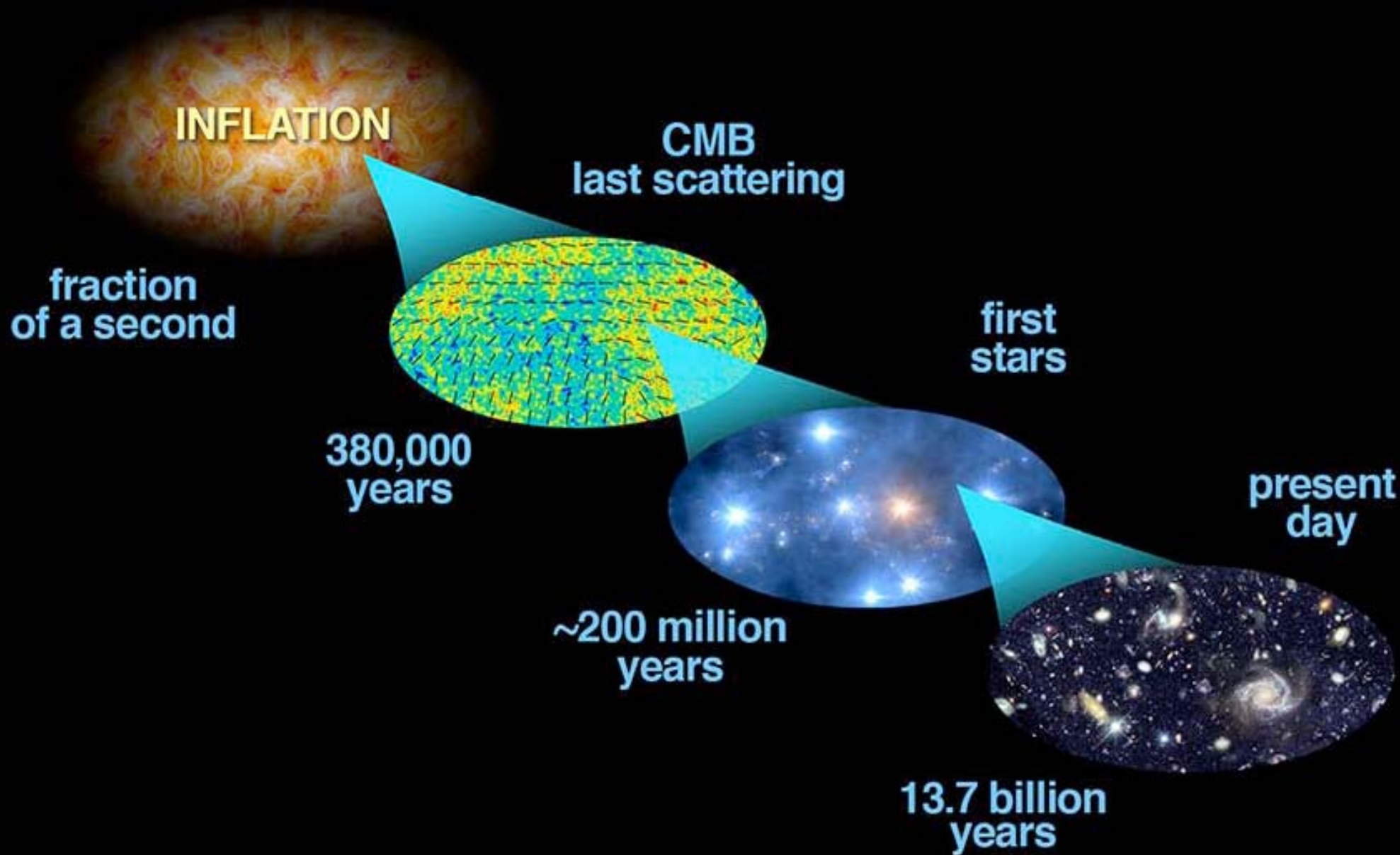

VOIR LOIN, C'EST VOIR LE PASSÉ LOINTAIN !

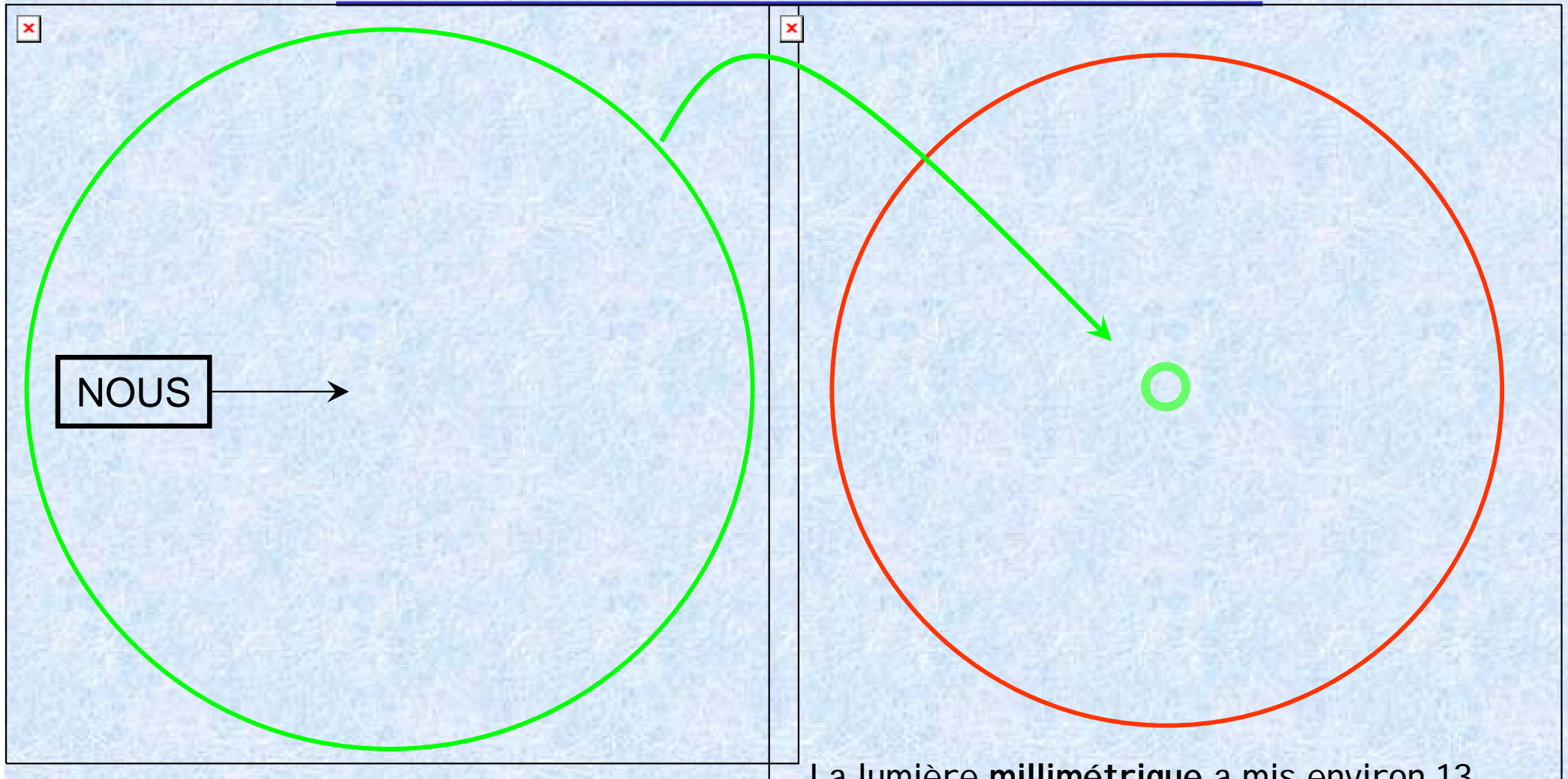

Chaque point est une galaxie comme la Notre. La plus proche, M31, est à ~2,5 Mal. Il faut 2,7 milliards d'années à la lumière d'une galaxie sur le cercle vert pour qu'elle nous parvienne.

La lumière **millimétrique** a mis environ 13 milliards d'années pour nous parvenir (cercle rouge).

C'est la trace intacte (comme fossilisée) de la fournaise primordiale, 400 000 ans après le Bang, quand l'Univers est devenu Transparent.

QUAND L'UNIVERS DEVIENT TRANSPARENT...

(at $\sim 1/3$ eV)

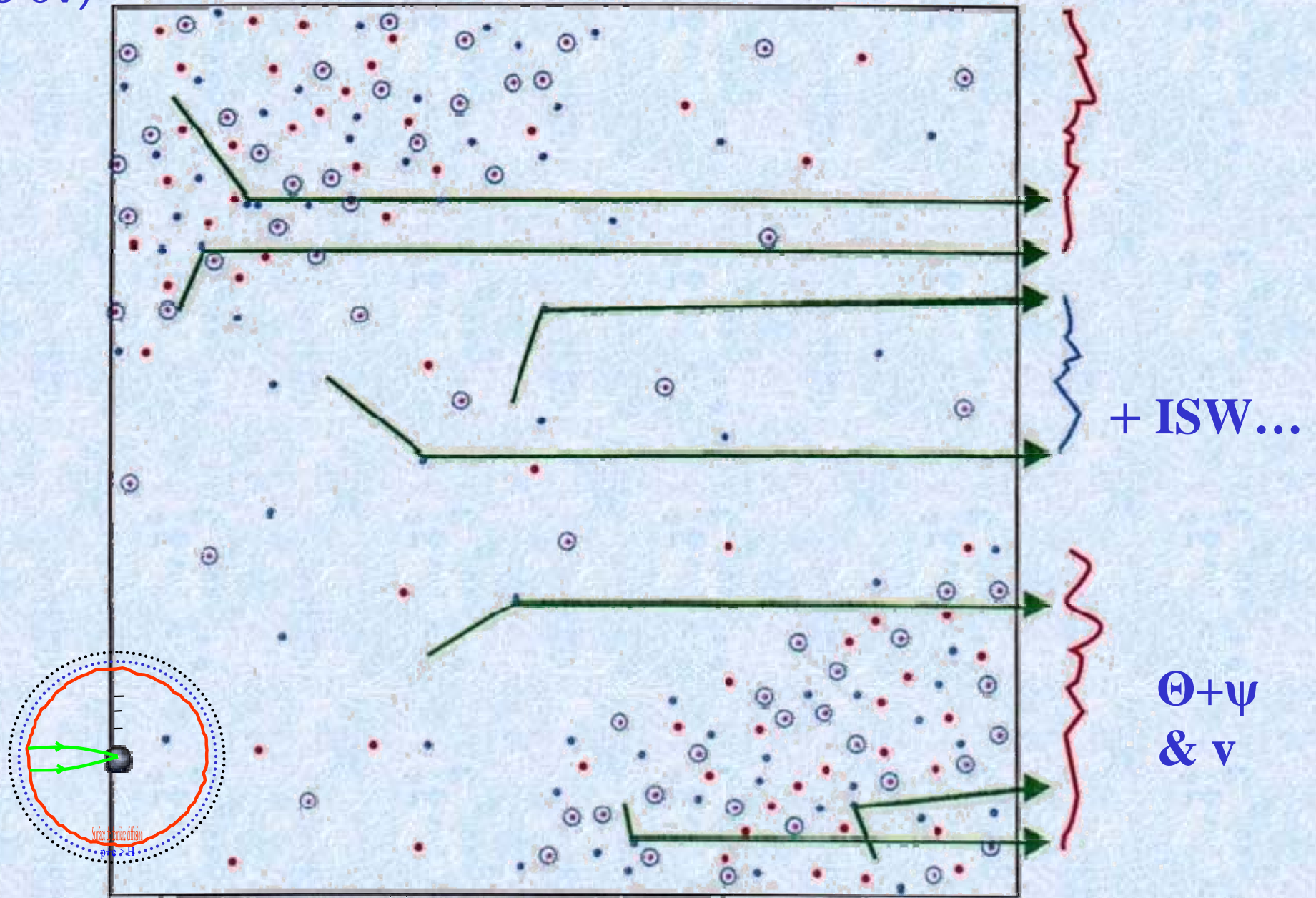

« COSMOMÉTRIE »: SPECTRE DE PUISSANCE ANGULAIRE DES ANISOTROPIES DE TEMPÉRATURE

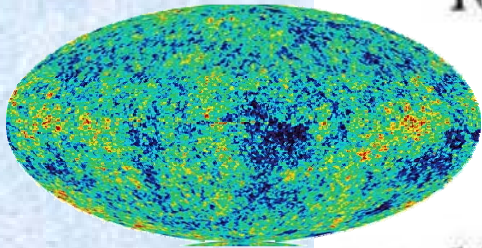

Hauteur des vagues / longueur d'onde l

NB1 : Ici, cas restreint de fluctuations Scalaires uniquement (sinon il existe un terme additionnel)
 NB2 : SW & ISW sont anti-corrélés

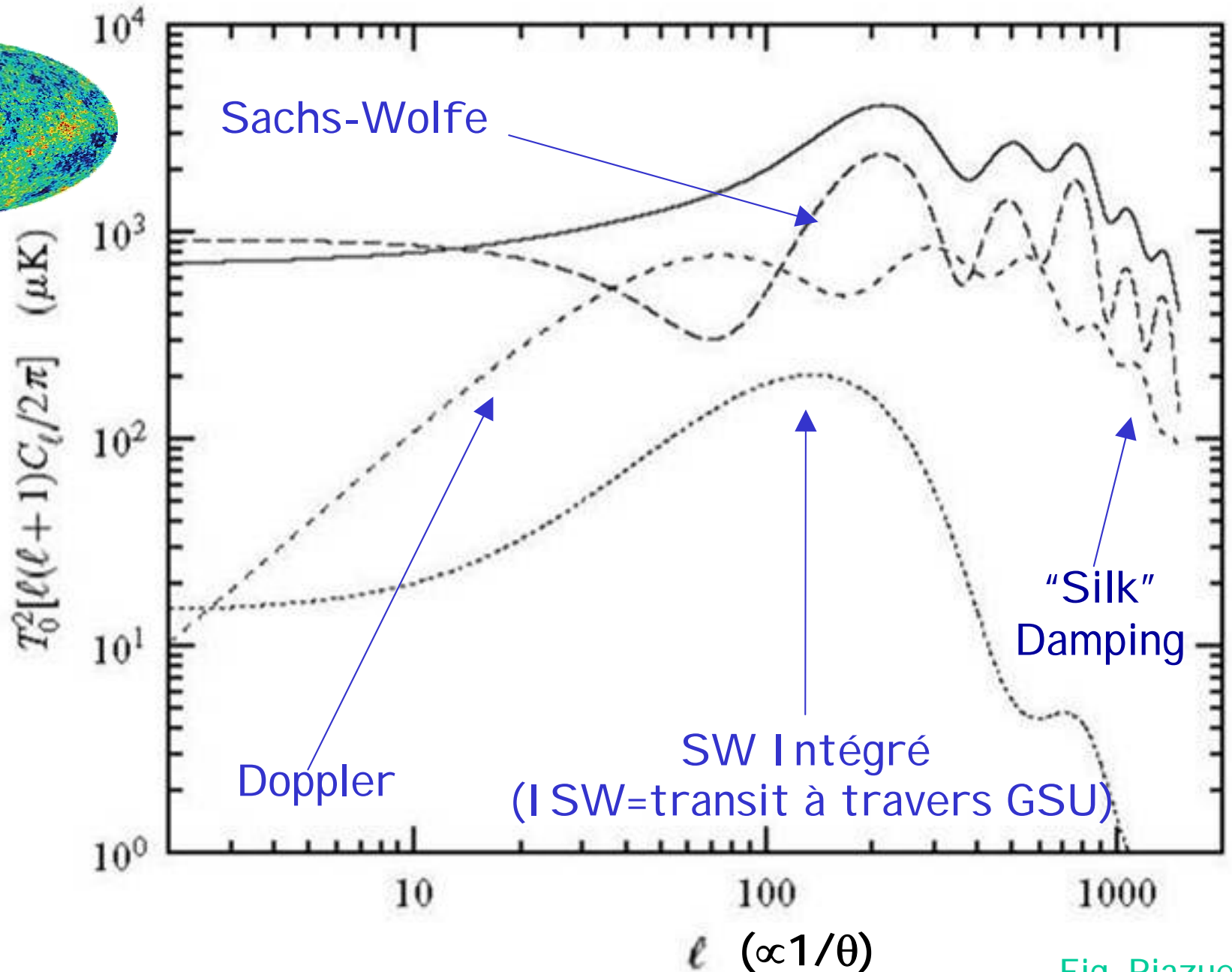
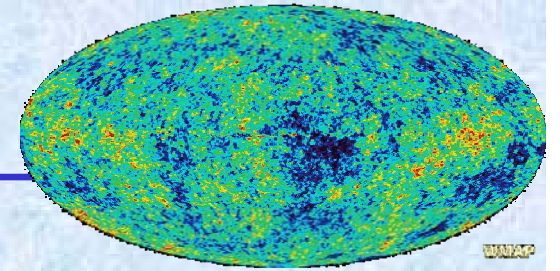

Fig. Riazuelo



OSCILLATIONS ACOUSTIQUES



$M > M_j$ non affectées

$M < M_j$ oscille

M_j

ΔZ_{dec}

l

temps

SDD



OSCILLATIONS ACOUSTIQUES

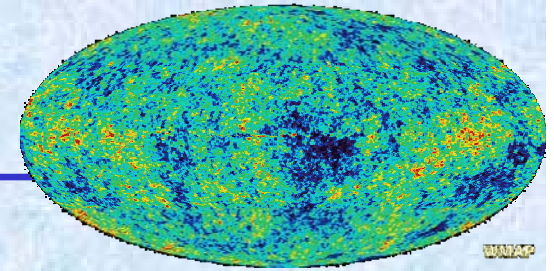

$M > M_J$ non affectées

M_J

$M < M_J$ oscille

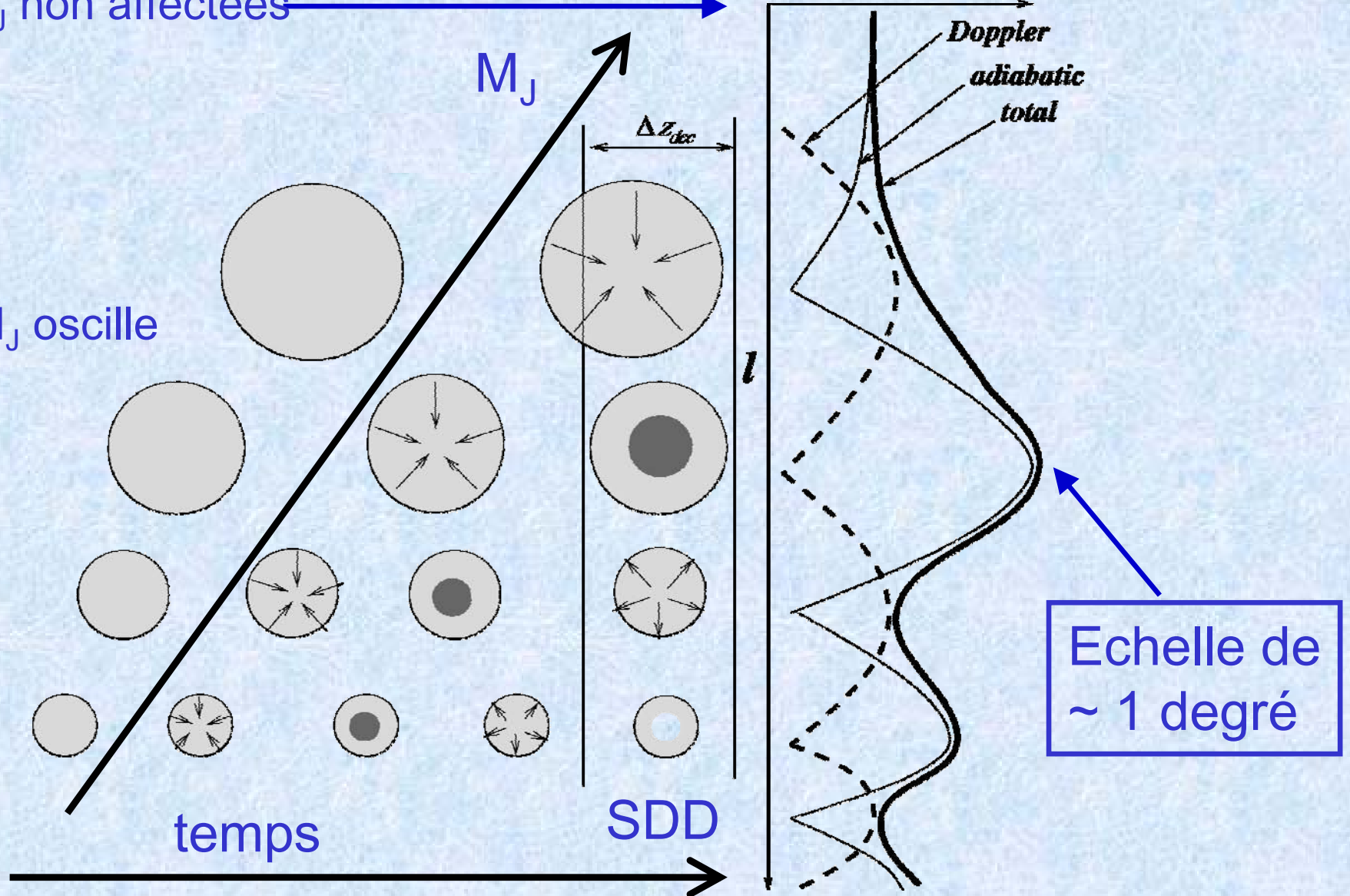

CE QU'ON OBSERVE

Carte lissée (suppression des échelles $\theta < 1$ deg) :

Fluctuations Quantiques imprimées quand l'âge de l'Univers était dans l'intervalle $[10^{-43}, 10^{-12}]$ seconds

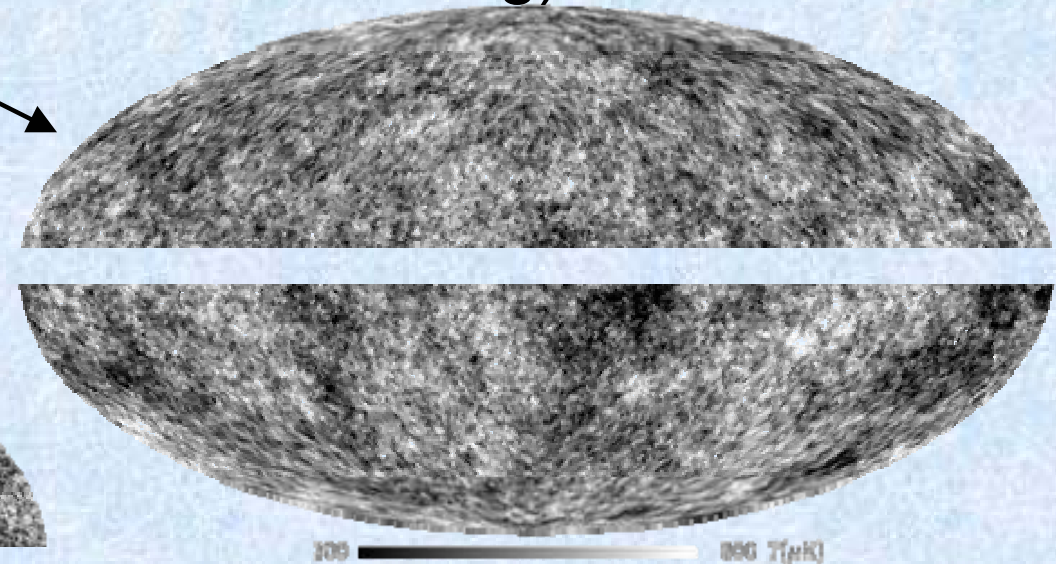
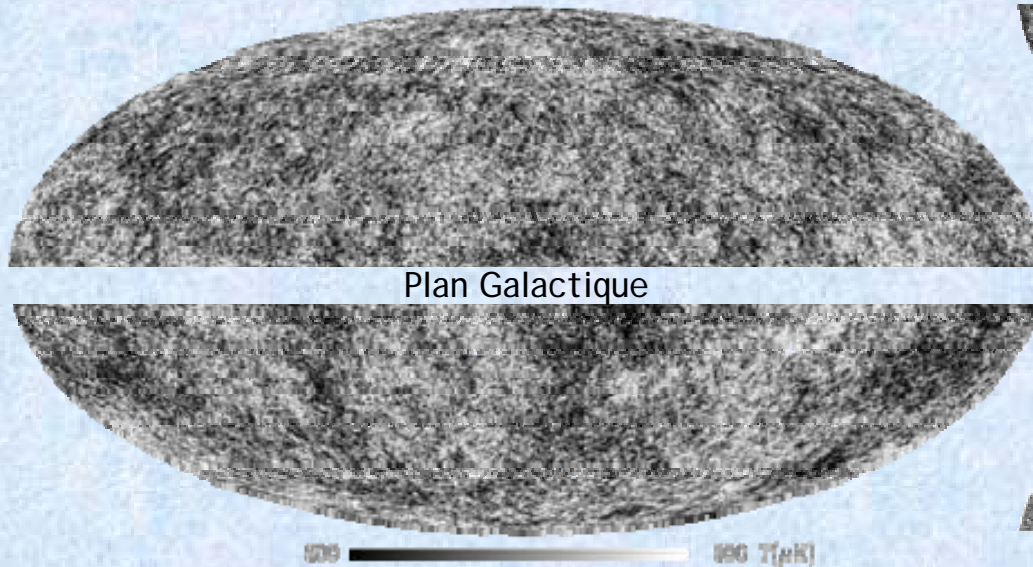

Carte différence (échelles $\theta < 1$ deg) :
Oscillations acoustiques aux petites échelles
< ct quand $t=370\,000$ ans (~ 150 Mpc aujourd'hui).
Permet de recenser le contenu

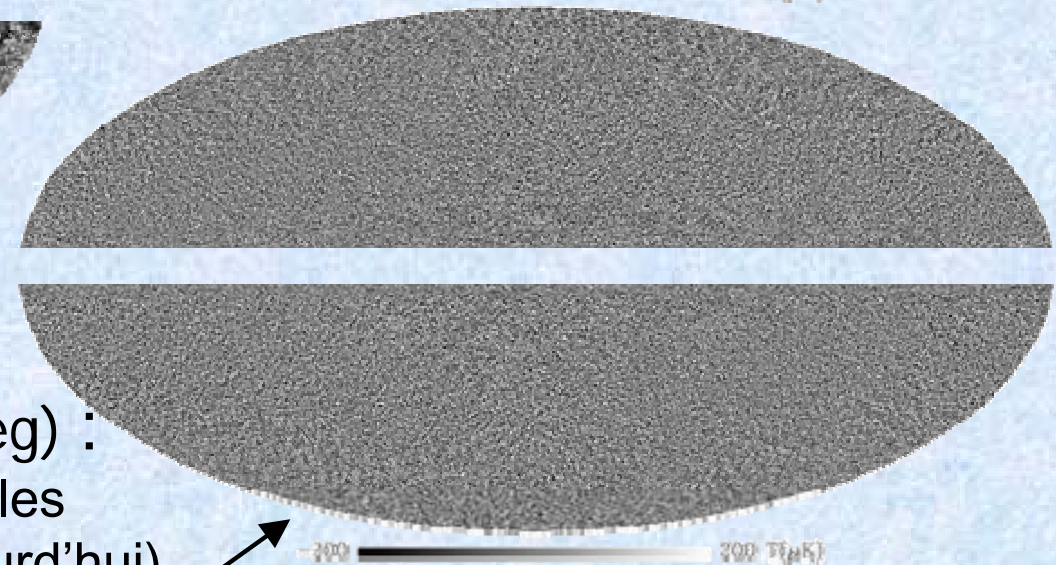

LES DIFFUSIONS THOMSON SONT POLARISÉES

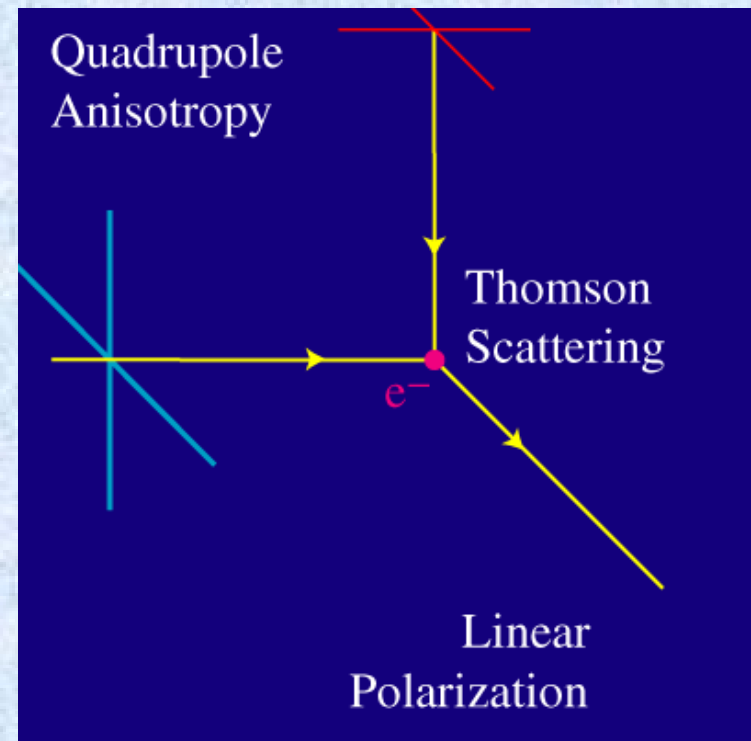
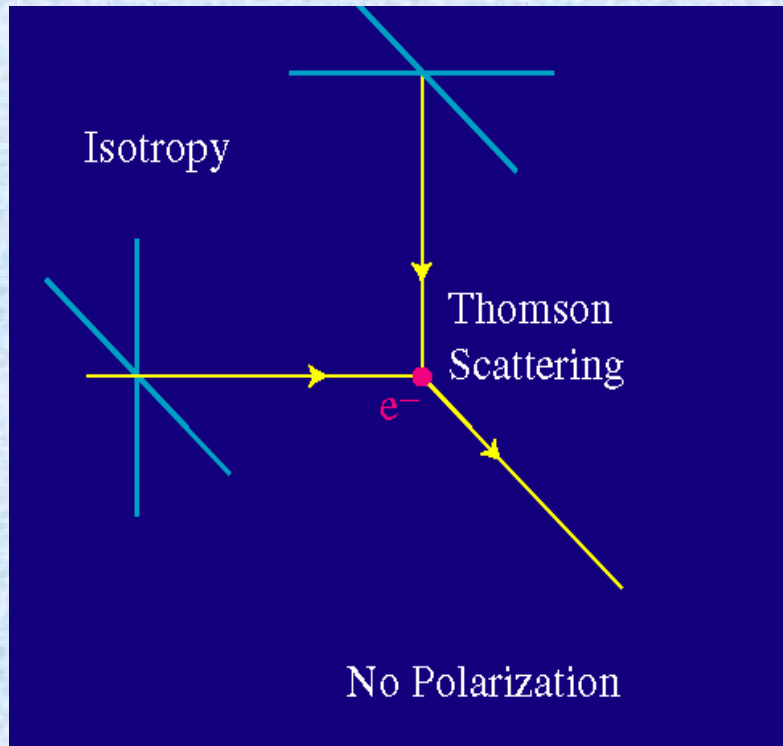
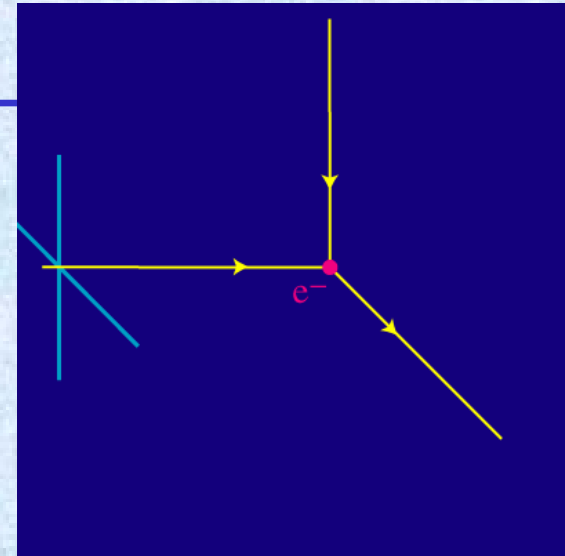

SPECTRES DE PUISSANCE DU RCF

3 observables : T, E, B

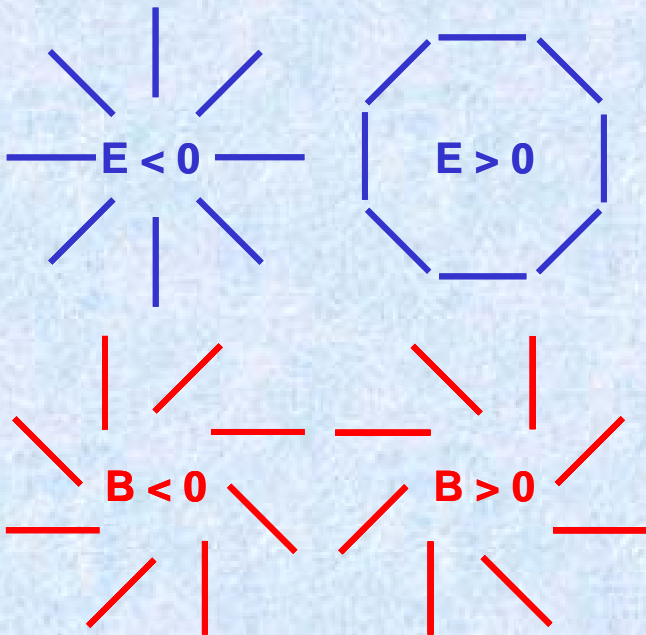

Les modes B ne peuvent pas être générés par des fluctuations primordiales scalaires mais « lentillage » par les grandes structures transforme du E en B

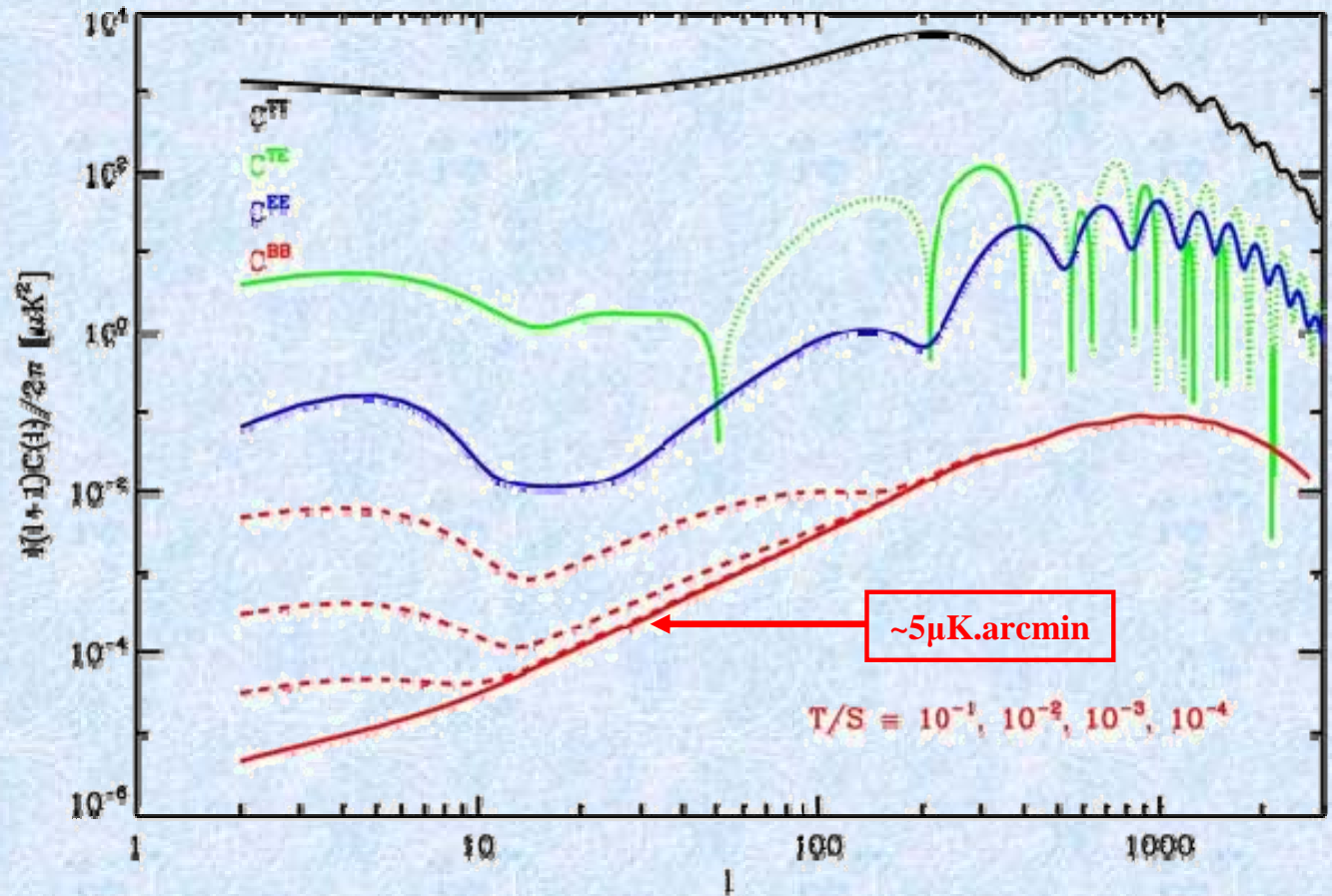

$(\propto 1/\theta)$

Ω_B
(D/H)

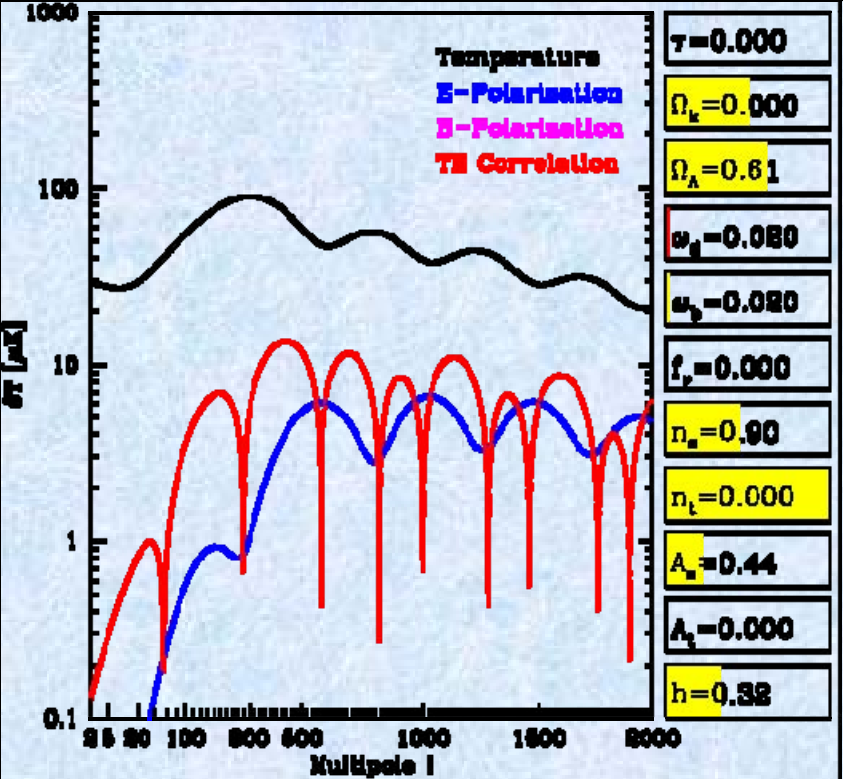
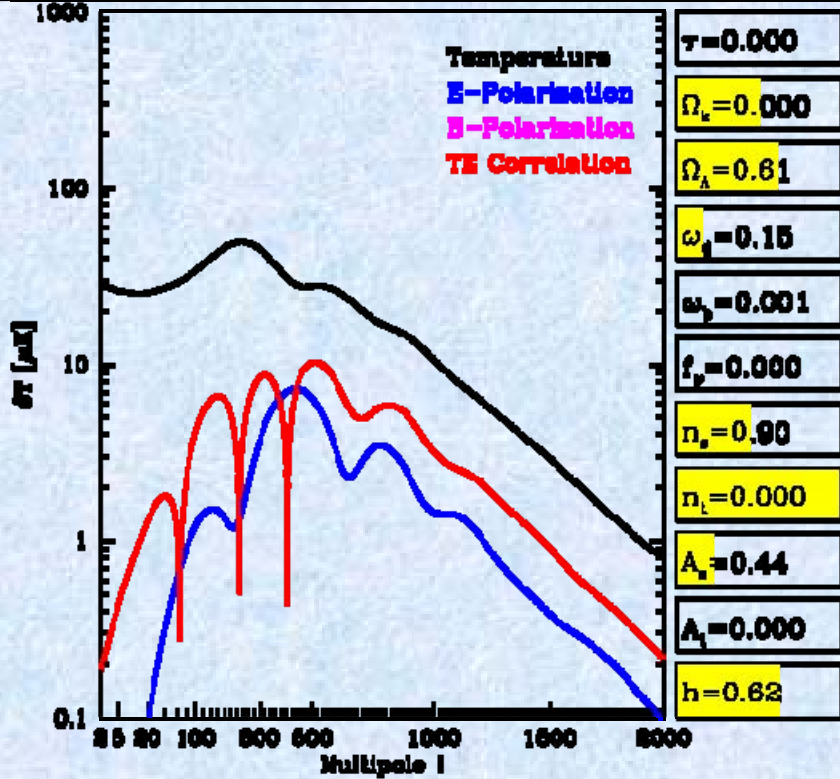

Ω_M
(LSS,
WL)

Tegmark's web site

Ω_A

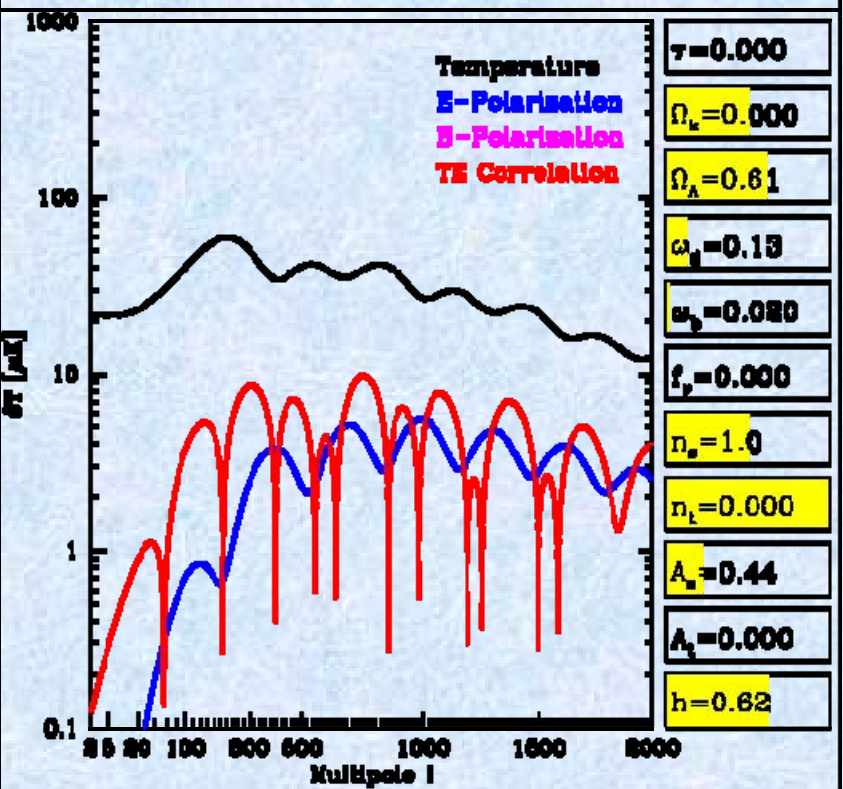
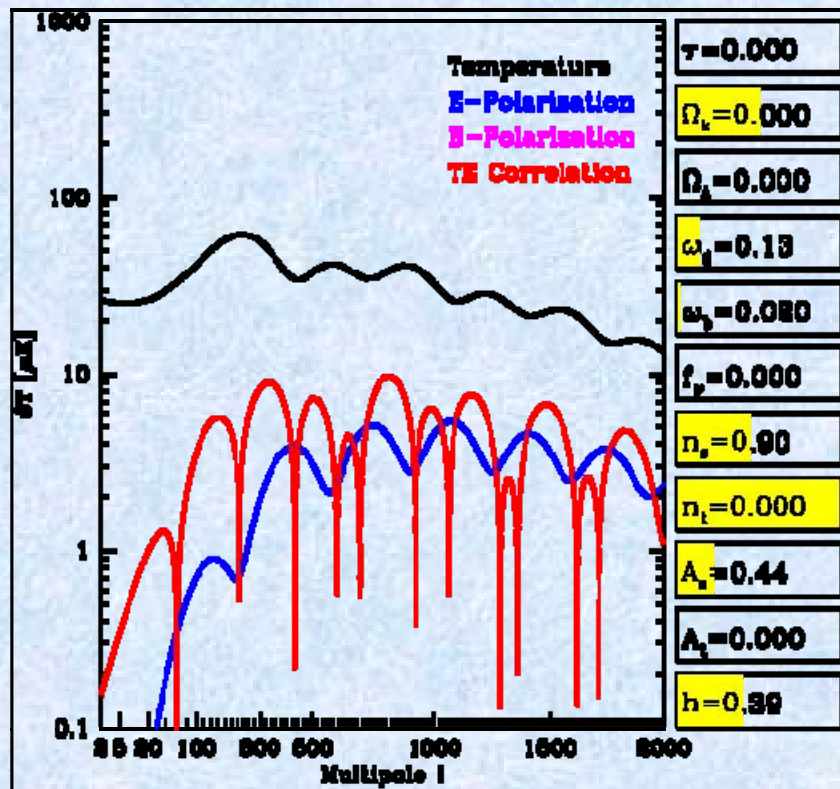

f_v
 $= \frac{\Omega_v}{\Omega_M}$

END OF 2002 STATUS...

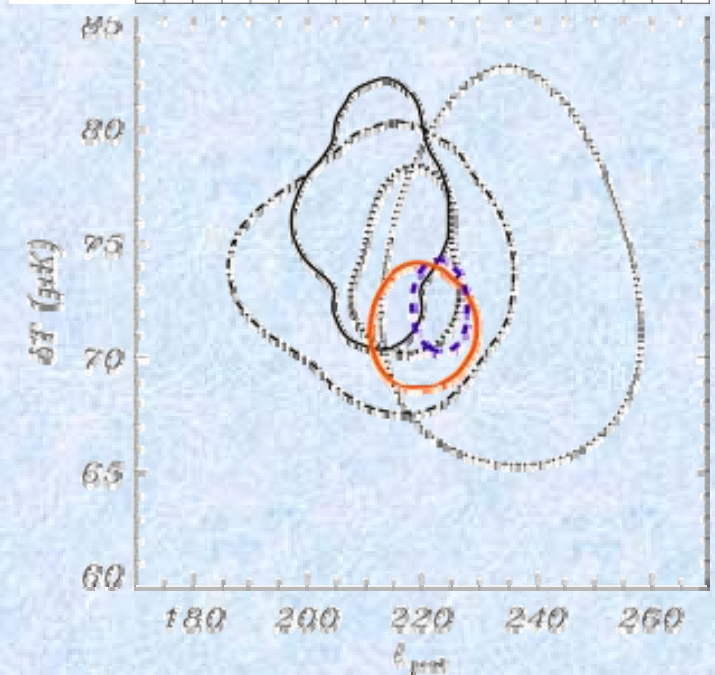
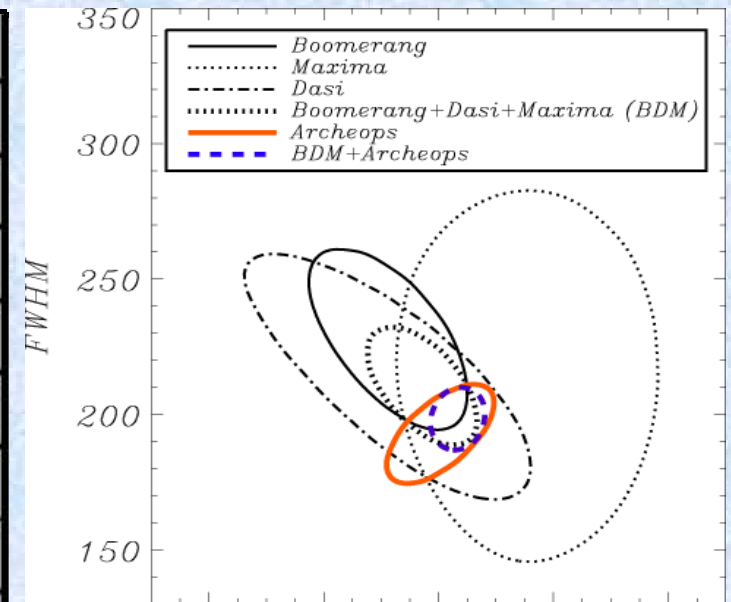
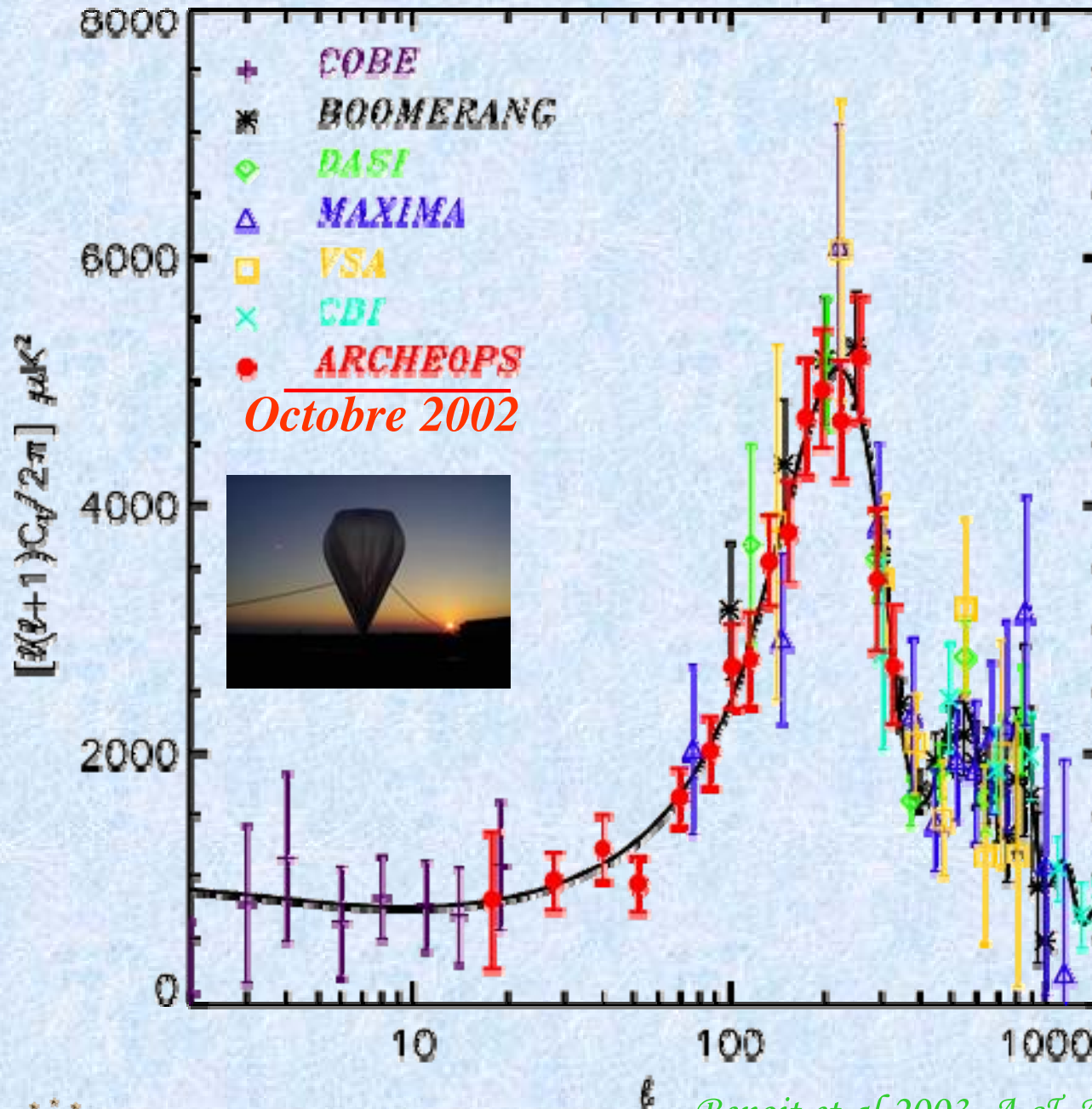

Benoit et al 2003, A & A, 399, L25



WMAP

WILKINSON MICROWAVE ANISOTROPY PROBE

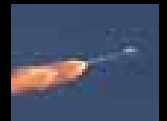
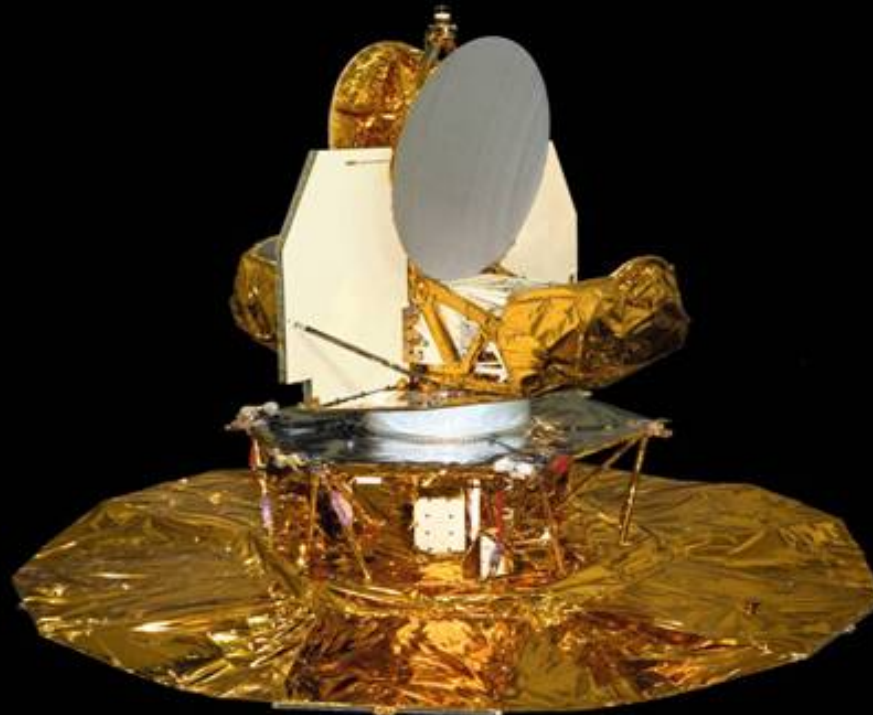

Launched on
June 30, 2001

HEMT BASED DIFFERENTIAL MEASURES

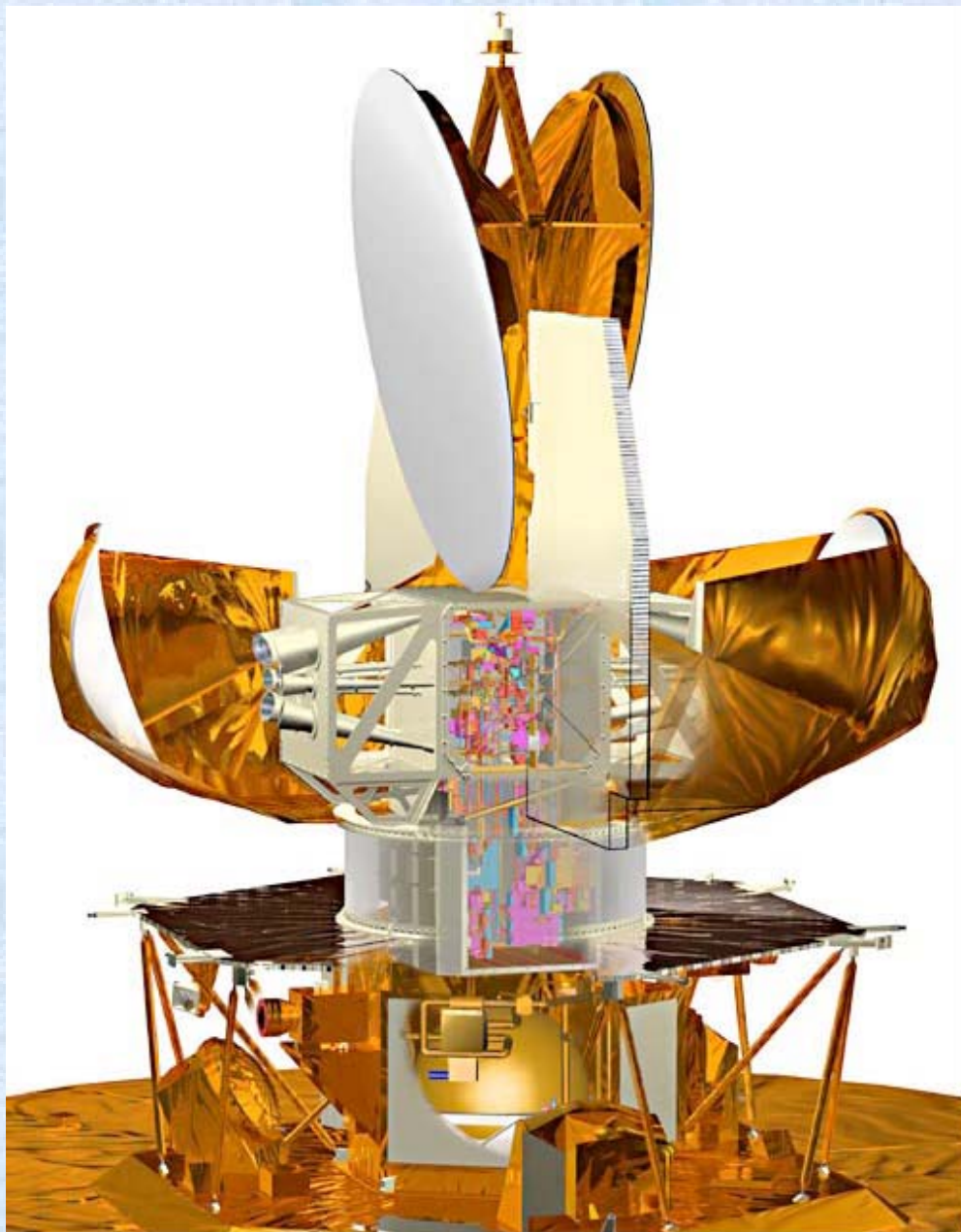

2 back-to-back telescopes

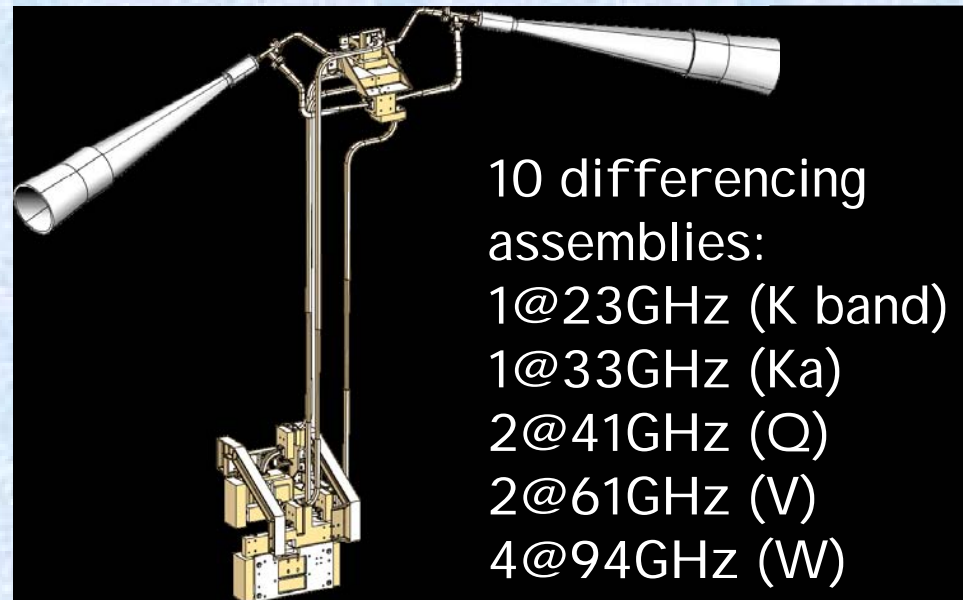

10 differencing
assemblies:
1@23GHz (K band)
1@33GHz (Ka)
2@41GHz (Q)
2@61GHz (V)
4@94GHz (W)

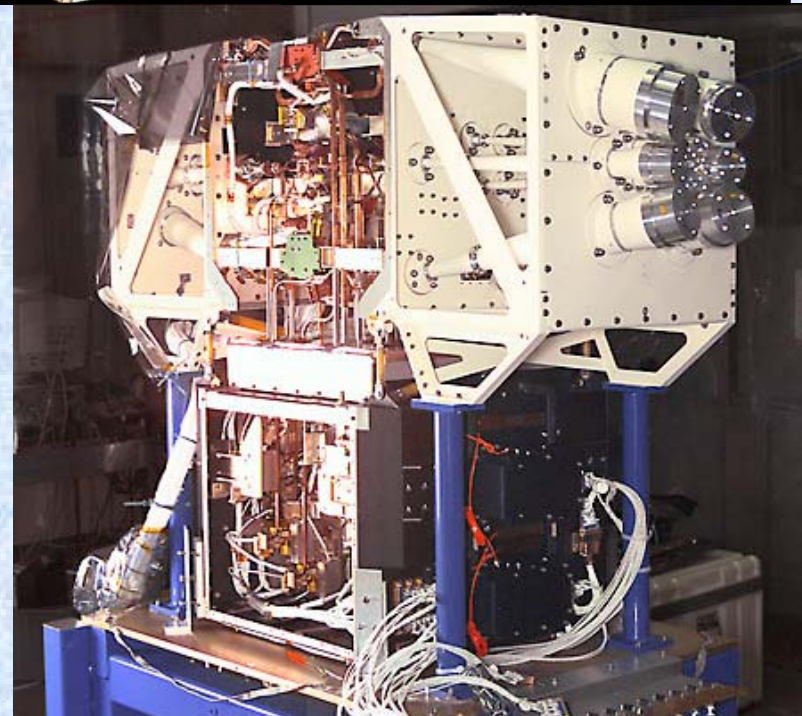

SCAN PATTERN

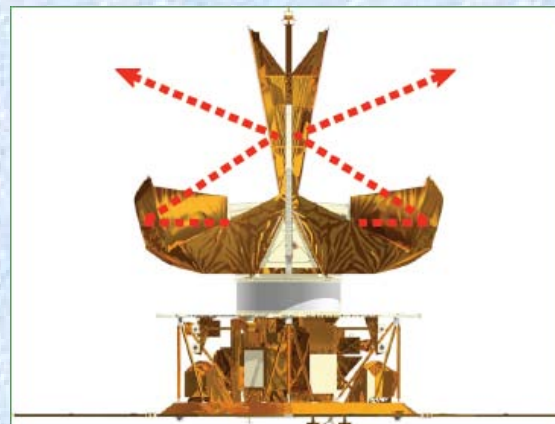
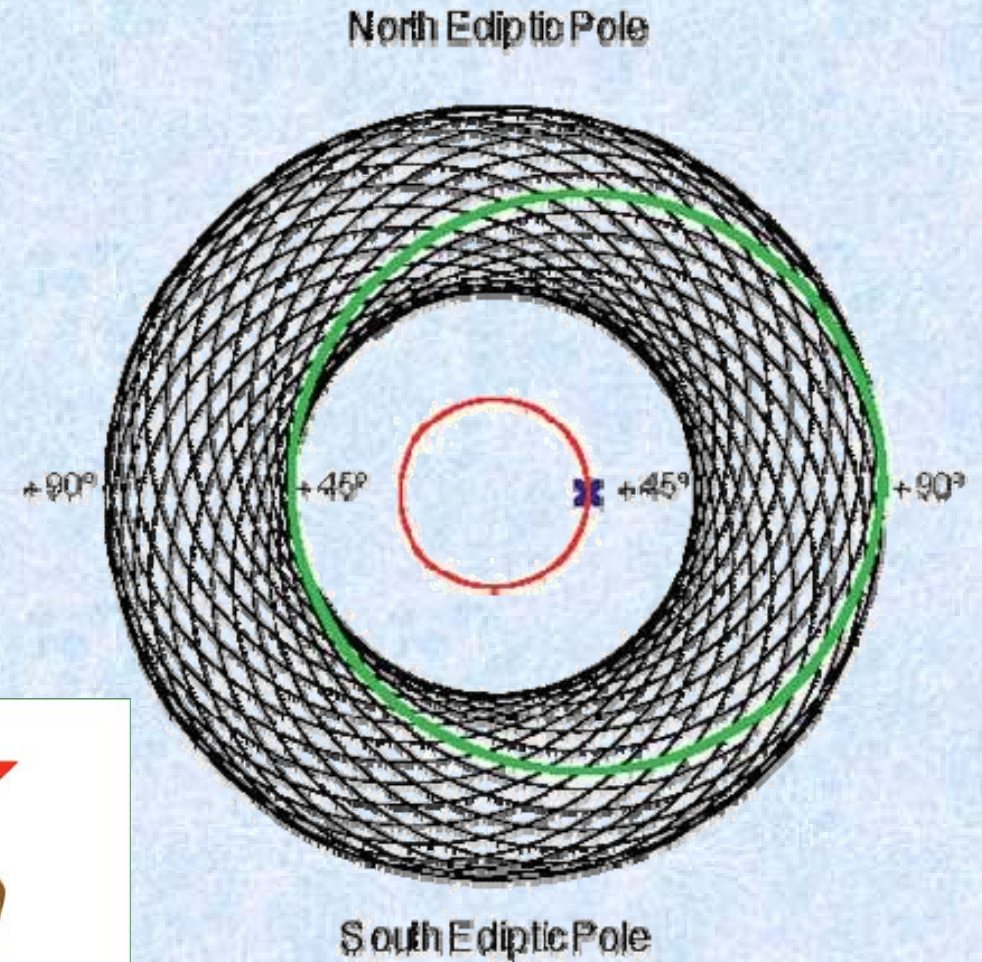
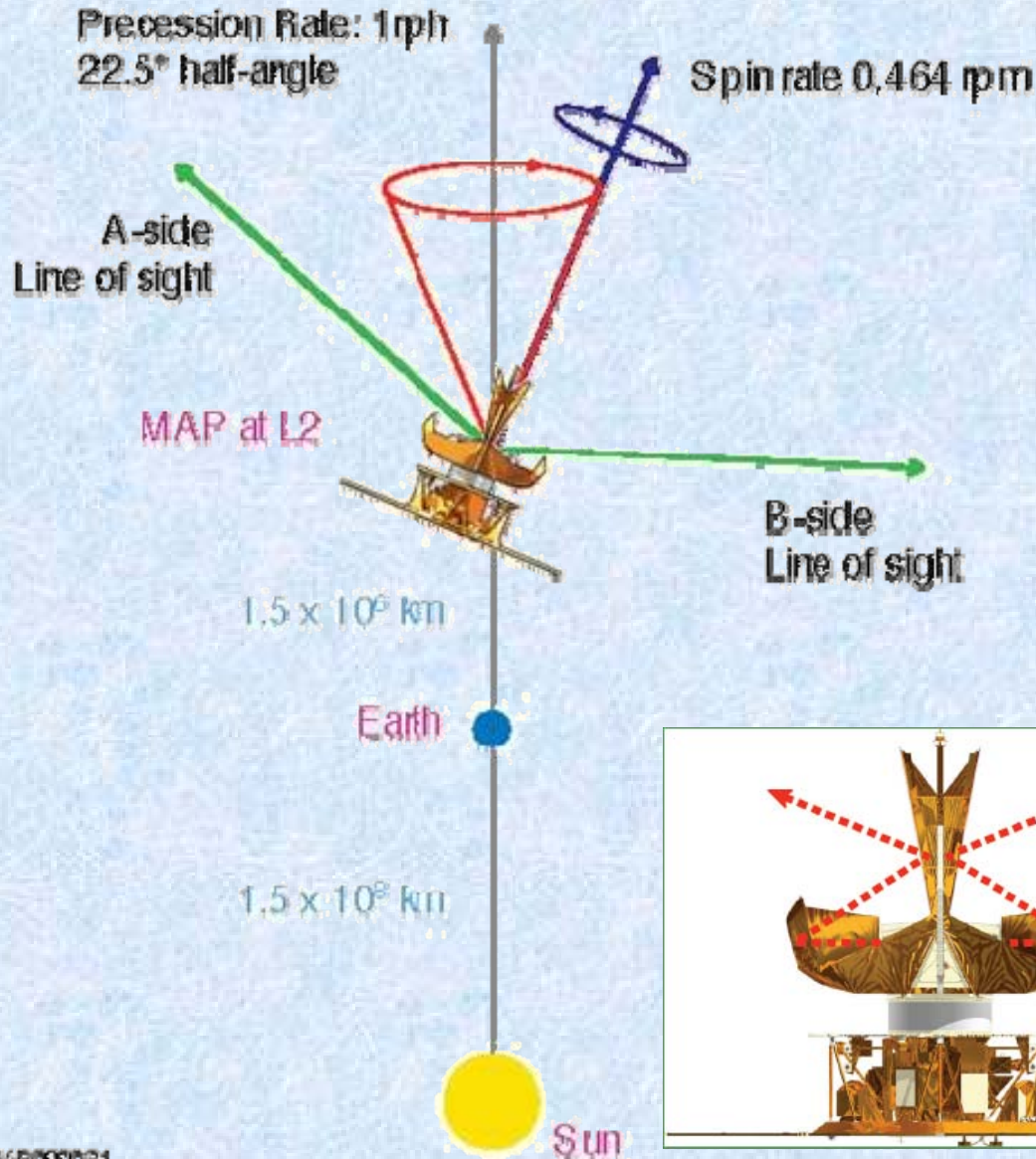
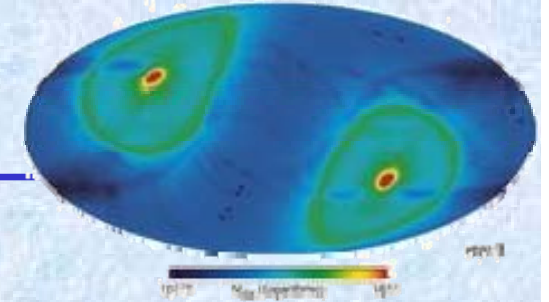

MAP990031



CONTINUOUS CALIBRATION FROM DIPOLE

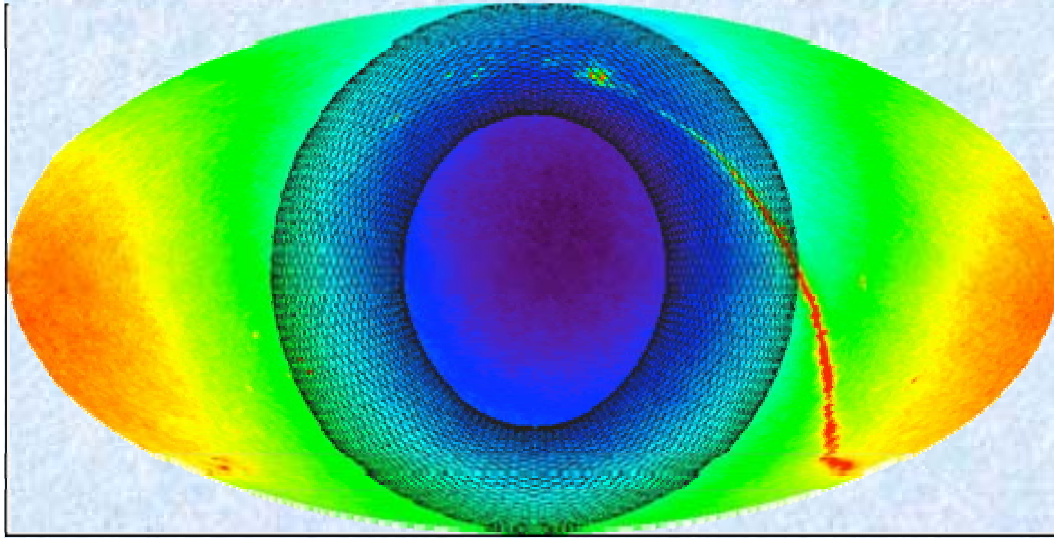

- + Gain calibration based on known dipole modulation due to motion of WMAP around the Sun.
- + CMB dipole provides short term transfer standard.
- + Baseline (or offset) determination based on sky signal changing sign every half-spin.

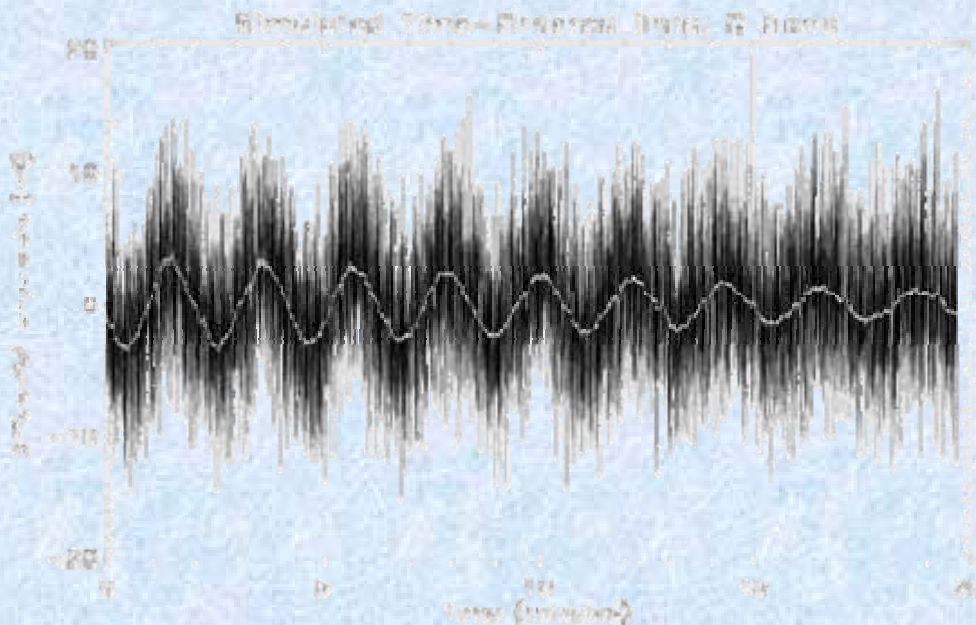

23GHz

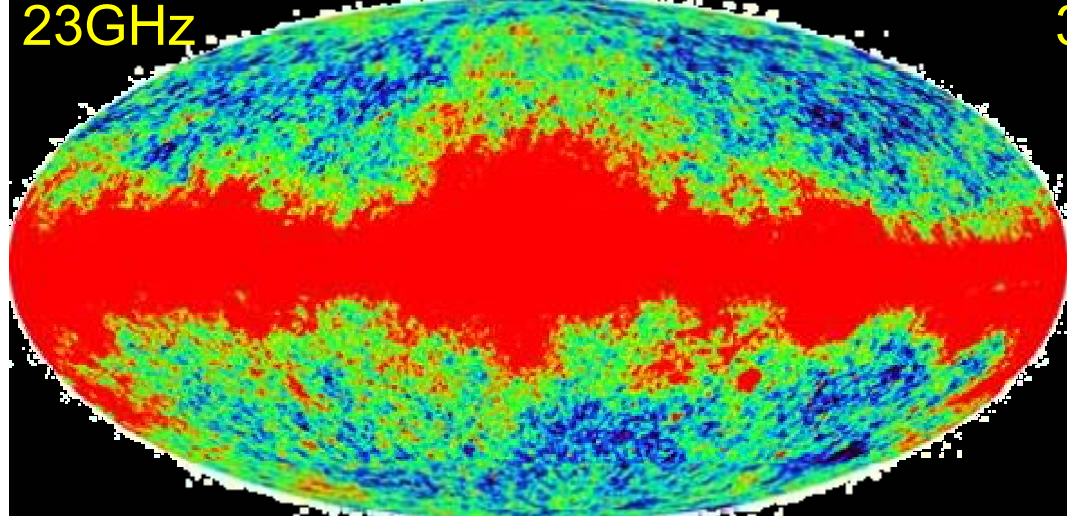

33GHz

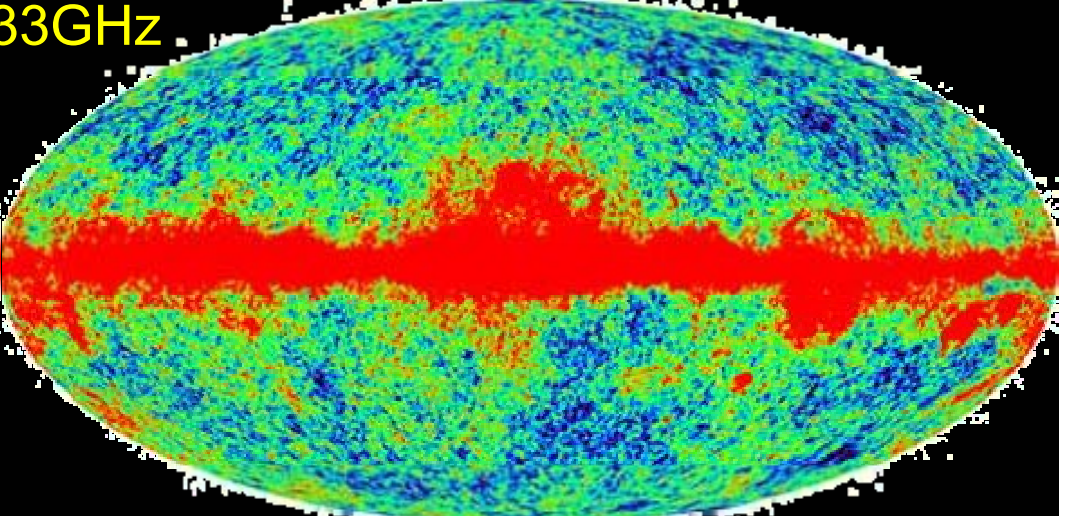

41GHz

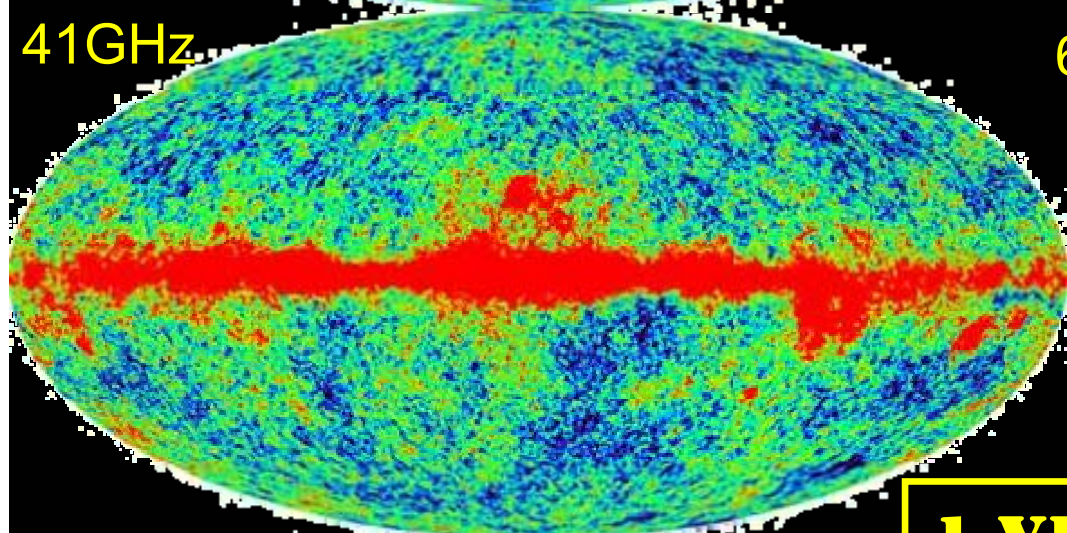

61GHz

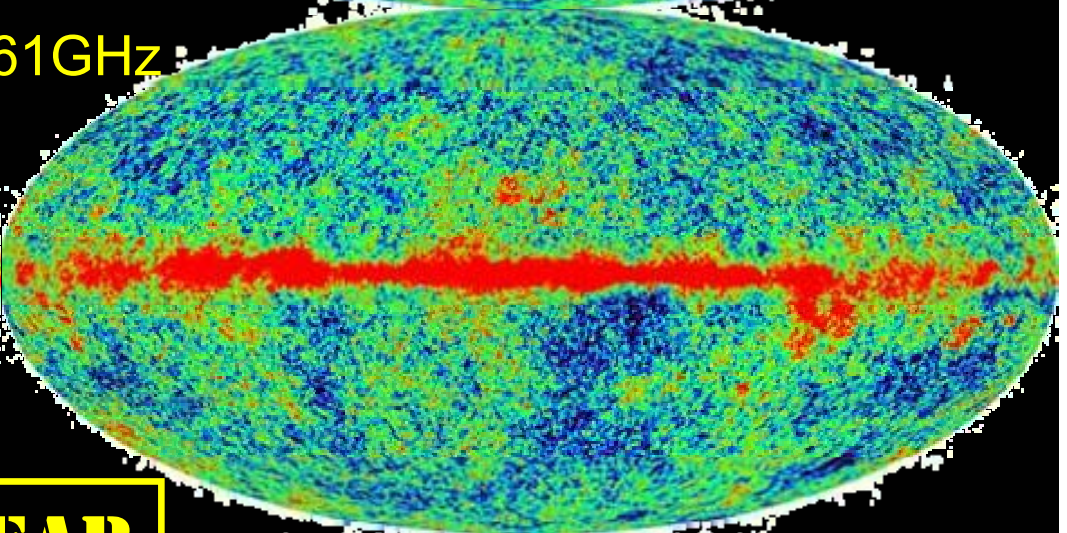

94GHz

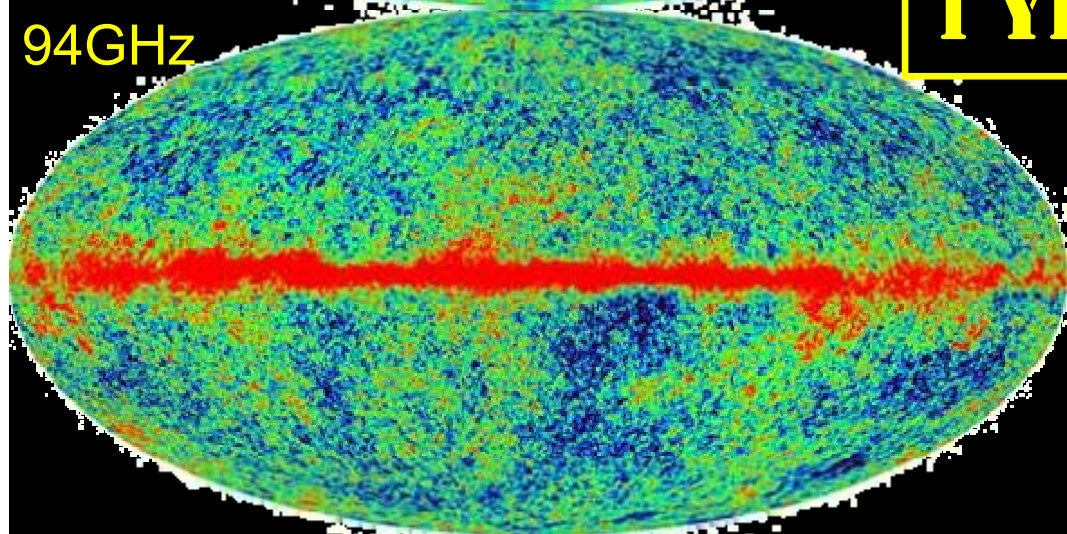

1 YEAR

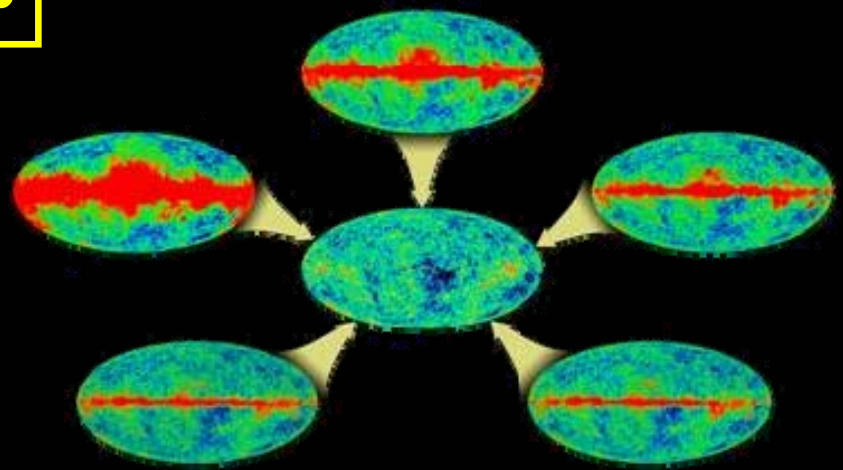

Cartes d'émission Déduites

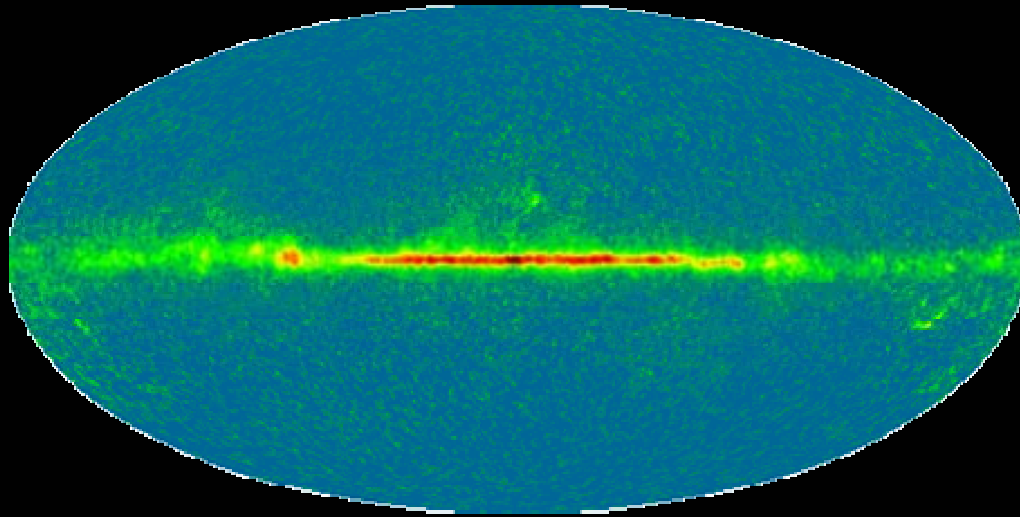

Poussière

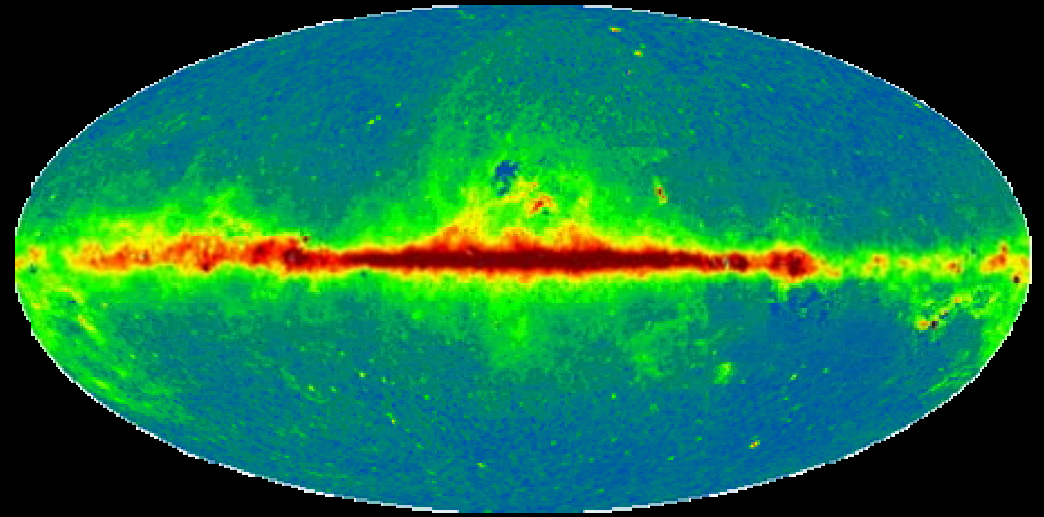

Synchrotron

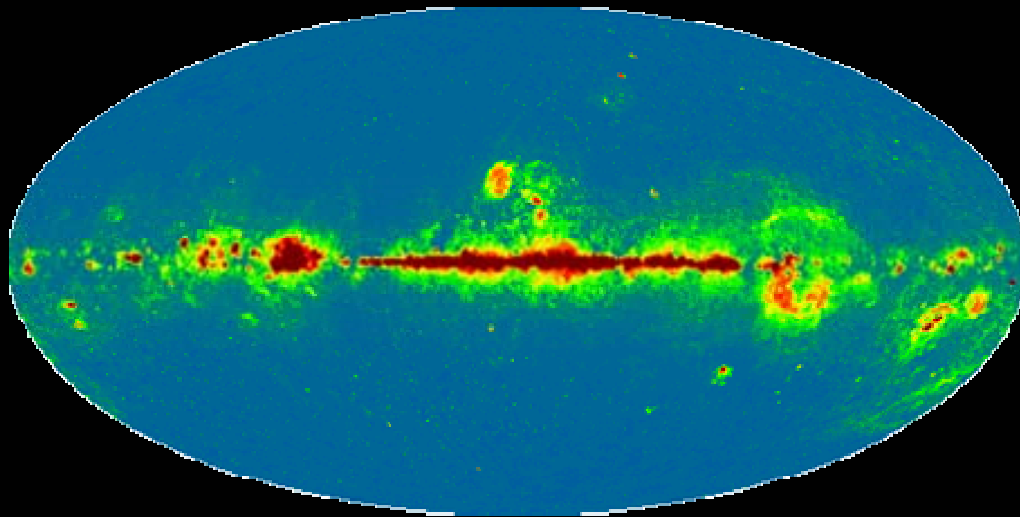

Bremstrahlung

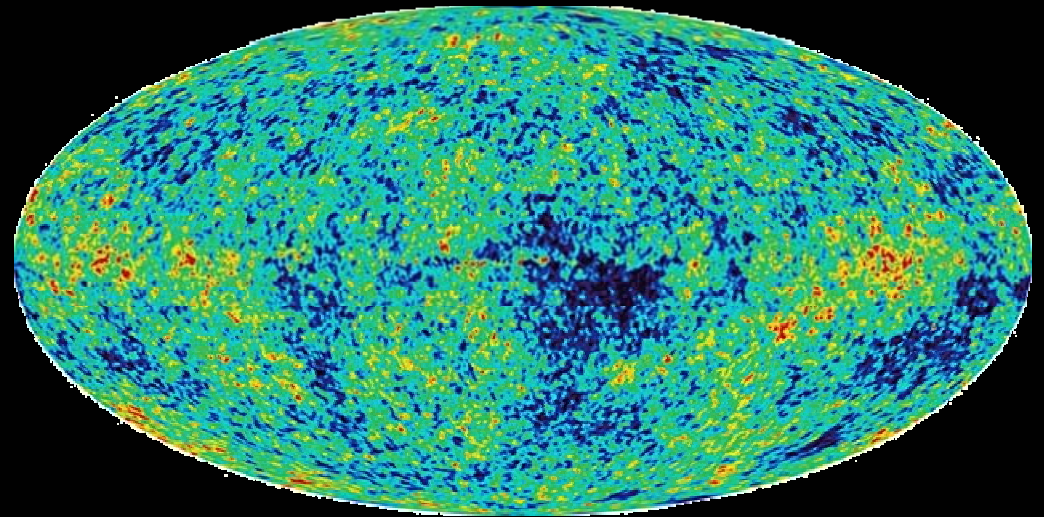

RCF

CARTE & SPECTRE DU RCF PAR WMAP-1

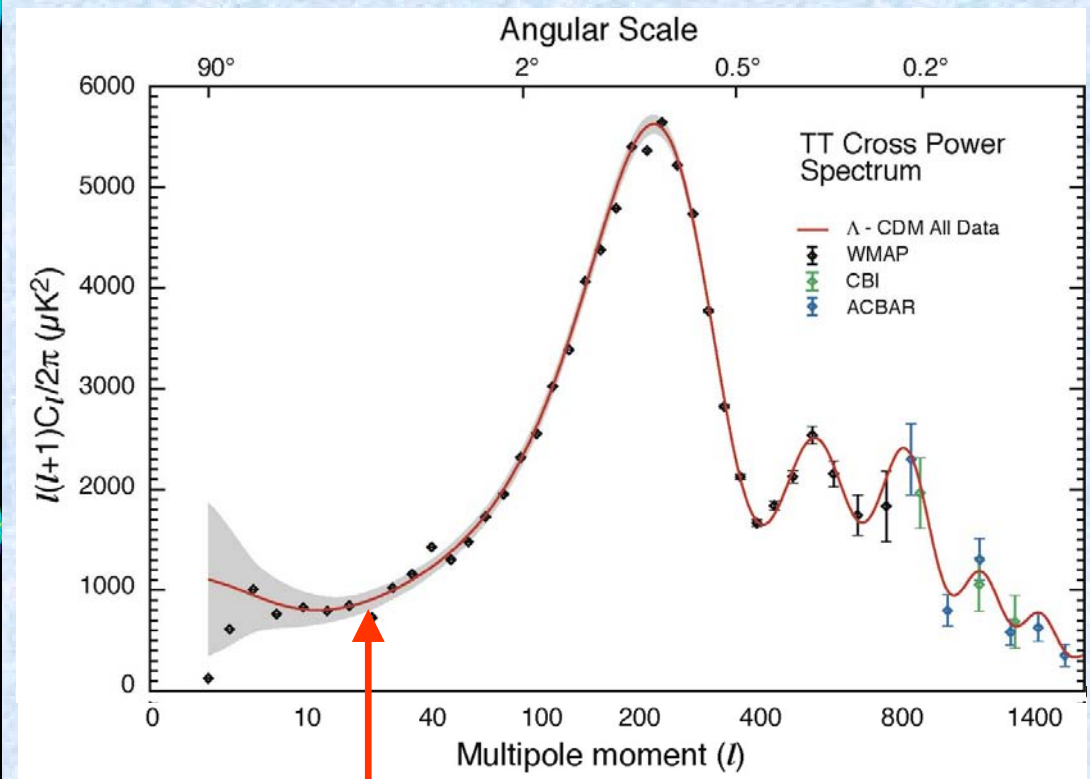
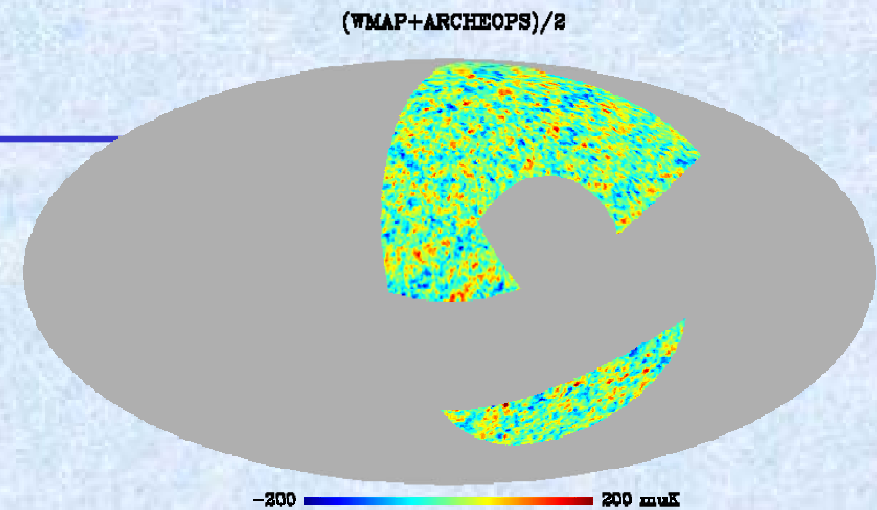
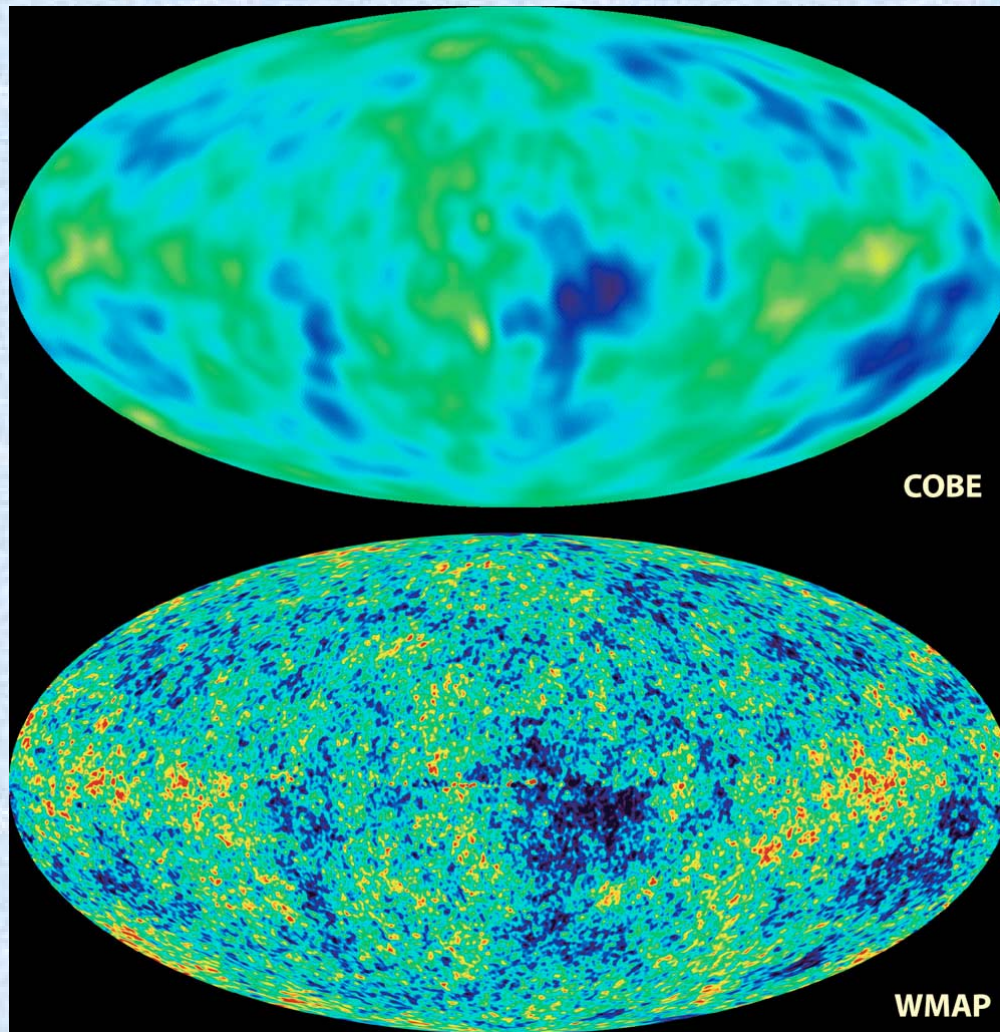

Courbe rouge = Théorie pour un univers avec 5% d'atomes, 25% de matière sombre, 70% d'énergie sombre



PRE-WMAP1 ↔ POST-WMAP1

Parameters very similar. Precision +

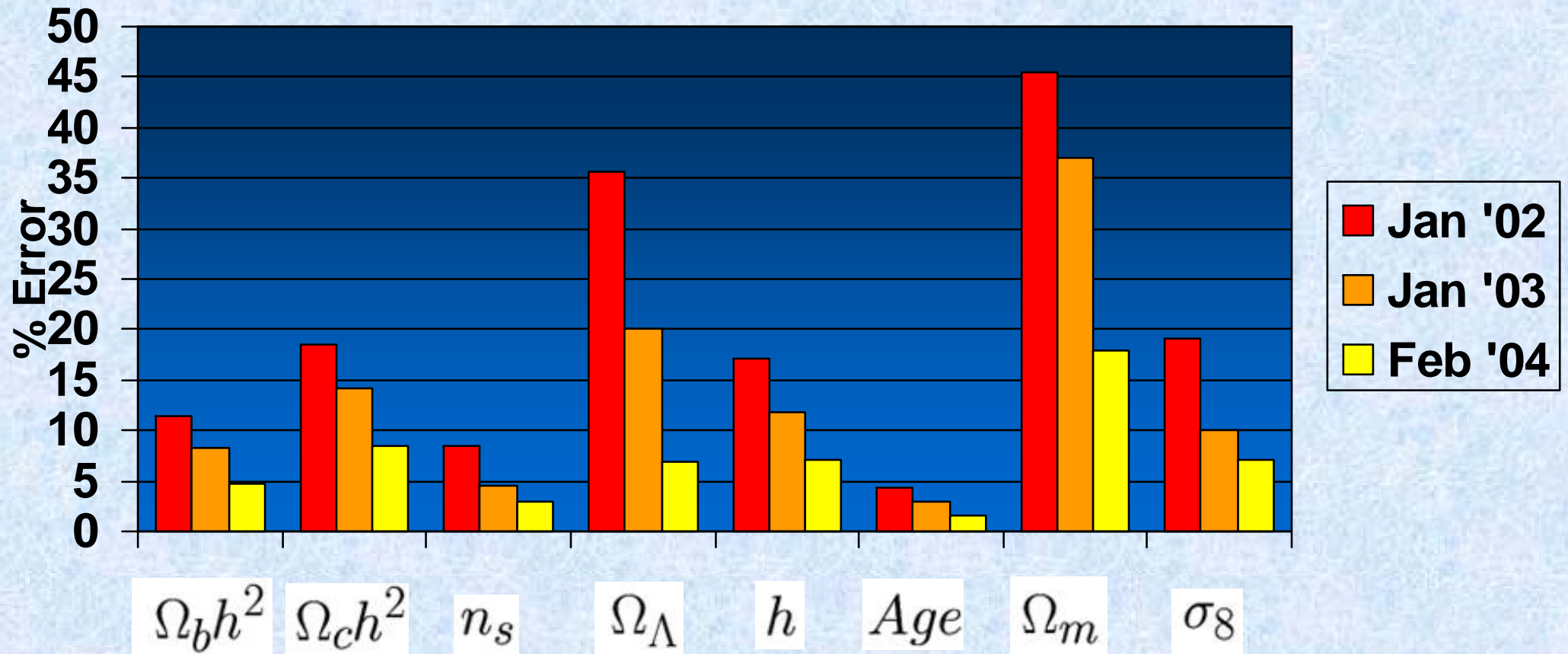

[Bond, Contaldi & Pogosyan astro-ph/0310735]

WMAP & LA POLARISATION

- # 1ere mesure du spectre de la polarisation (partie corrélée avec la Température, dite TE)
- # Oscillations / comparaison au même modèle théorique (courbe rouge): **consolidation supplémentaire du paradigme**
- # Le pic à bas l (grandes échelles) est **très haut** : **Réionisation de l'Univers plus tôt que prévu**. Fortes contraintes sur la sortie de l'âge sombre si confirmé
- # **Adiabaticité** des fluctuations primordiales (phases TT/TE)

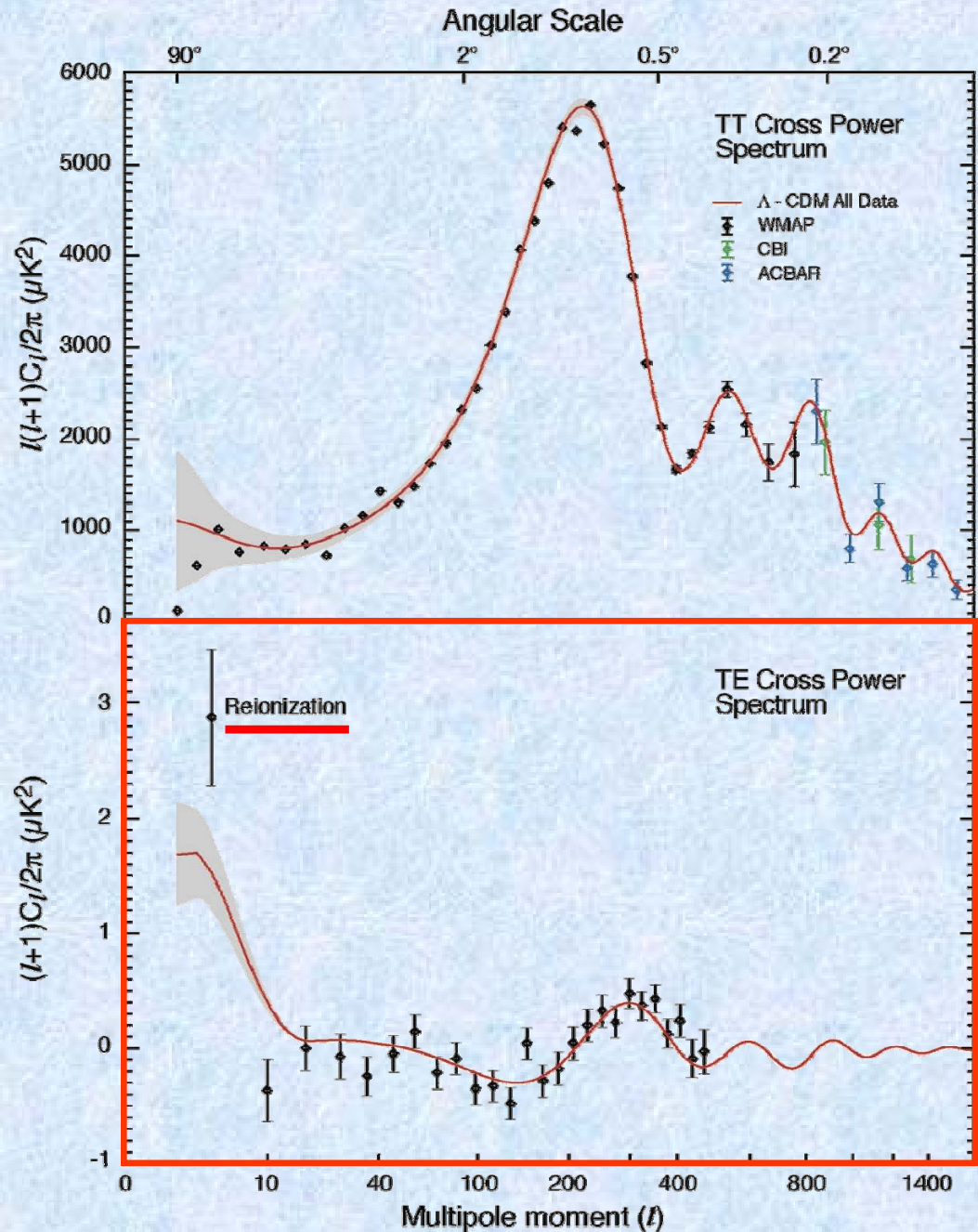

CONSISTENCY / COMPLEMENTARITY

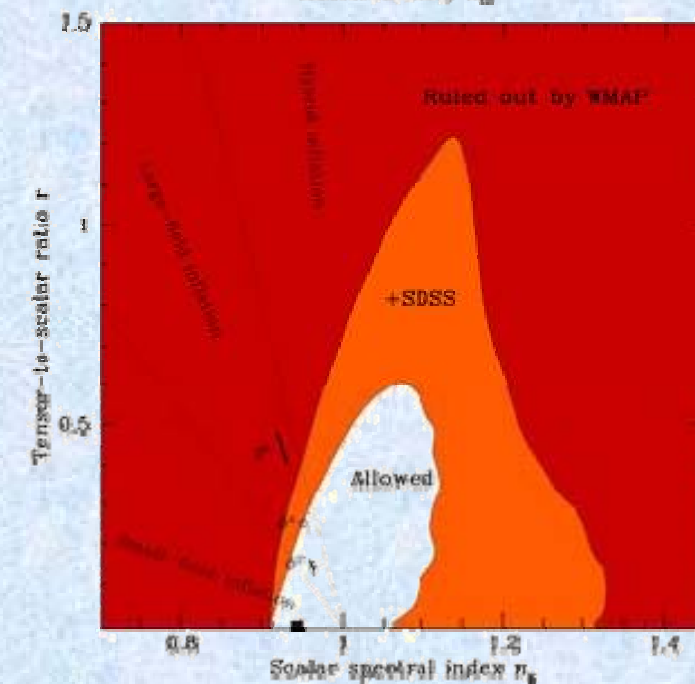
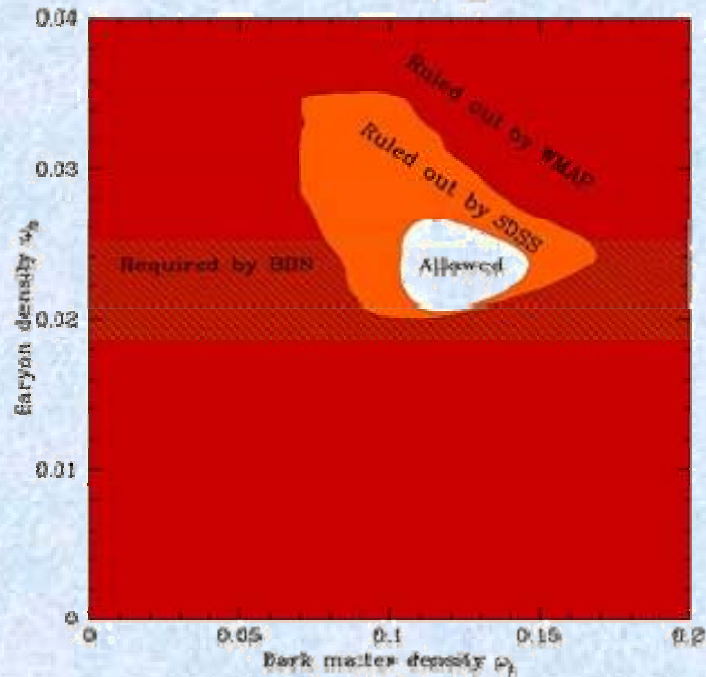
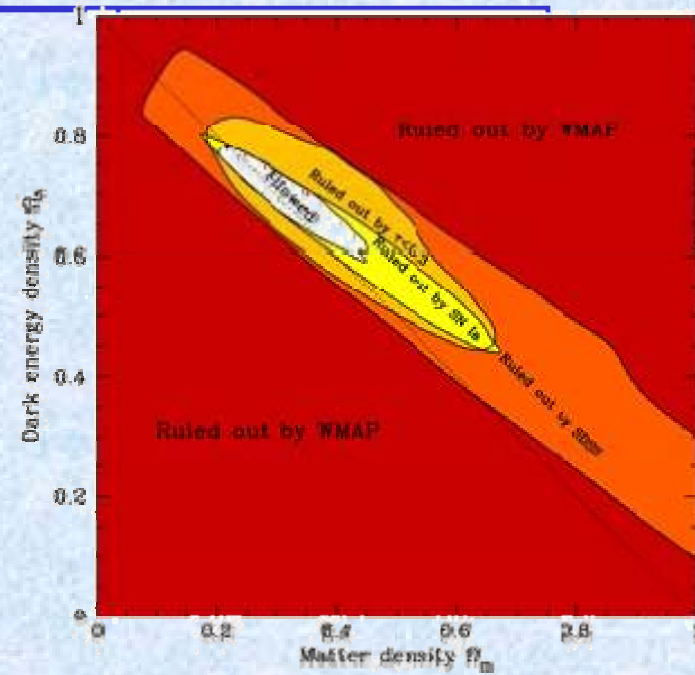
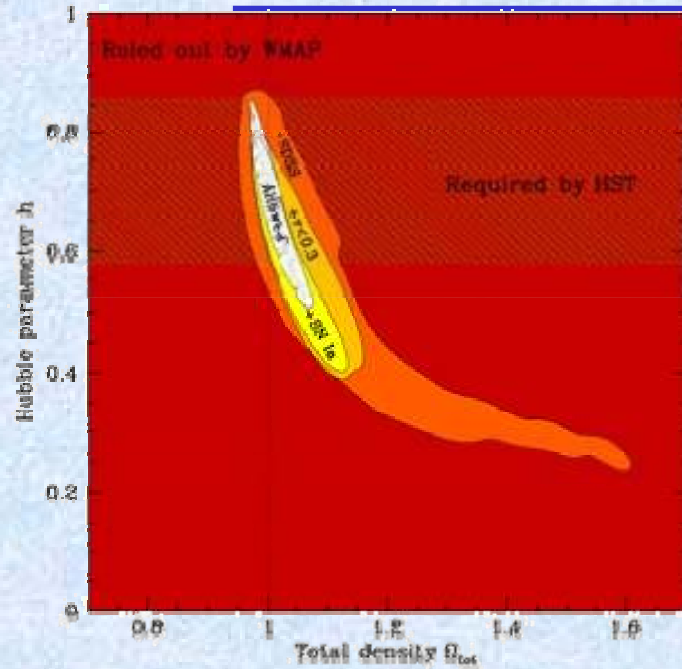

PRE-WMAP3 STATUS

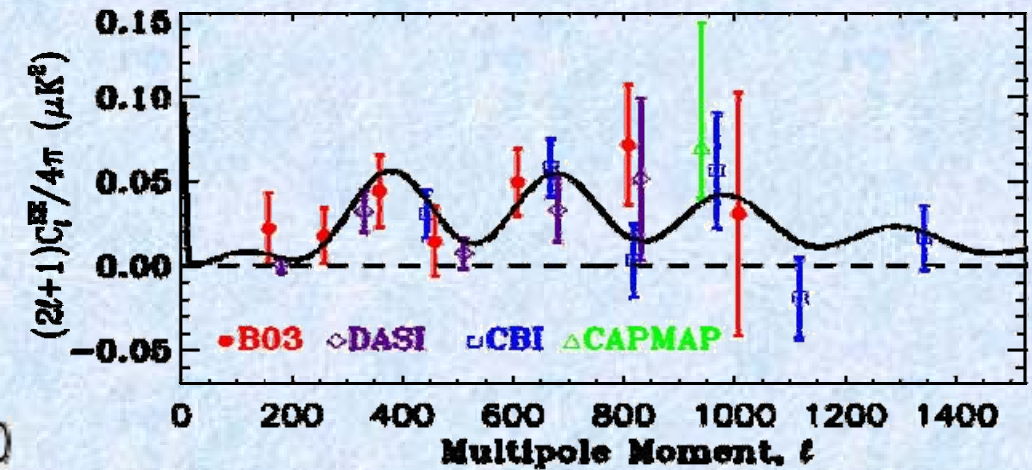
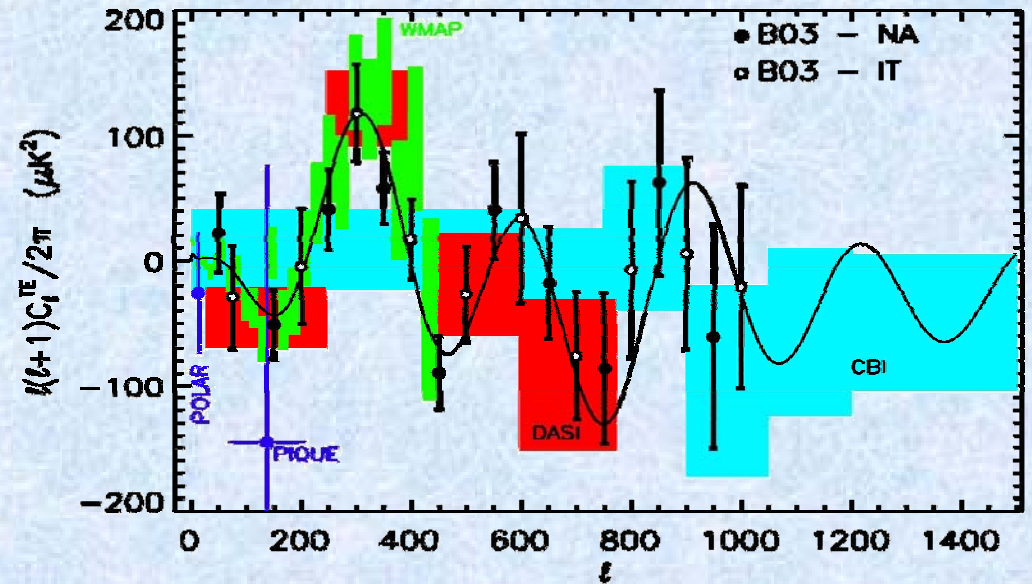
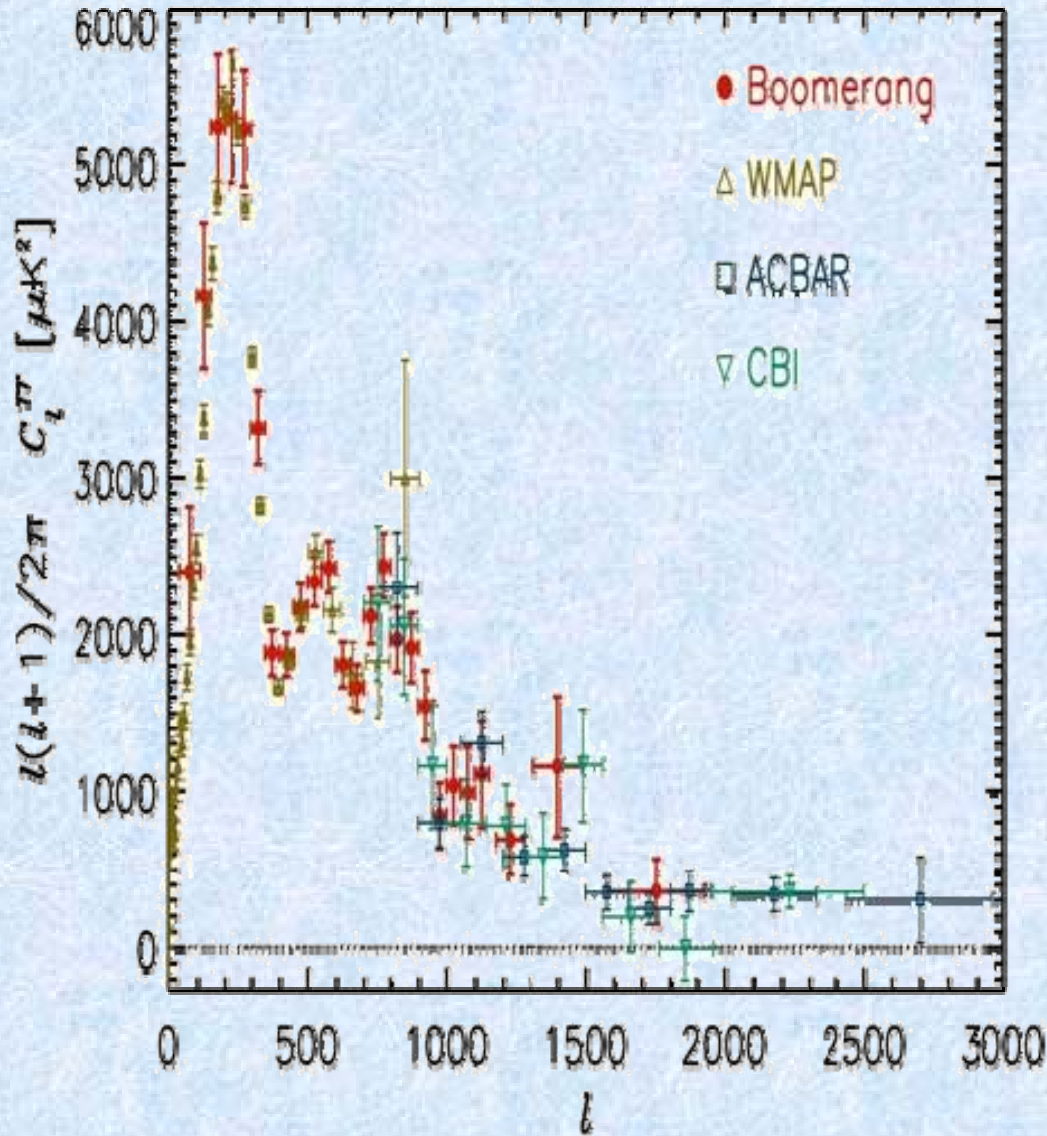
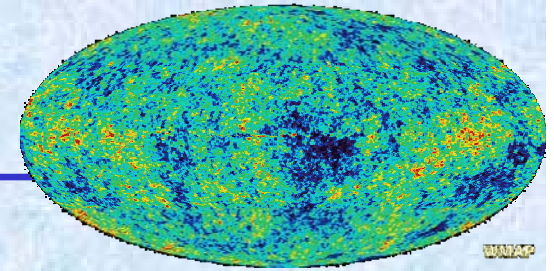

WMAP 3 YEARS

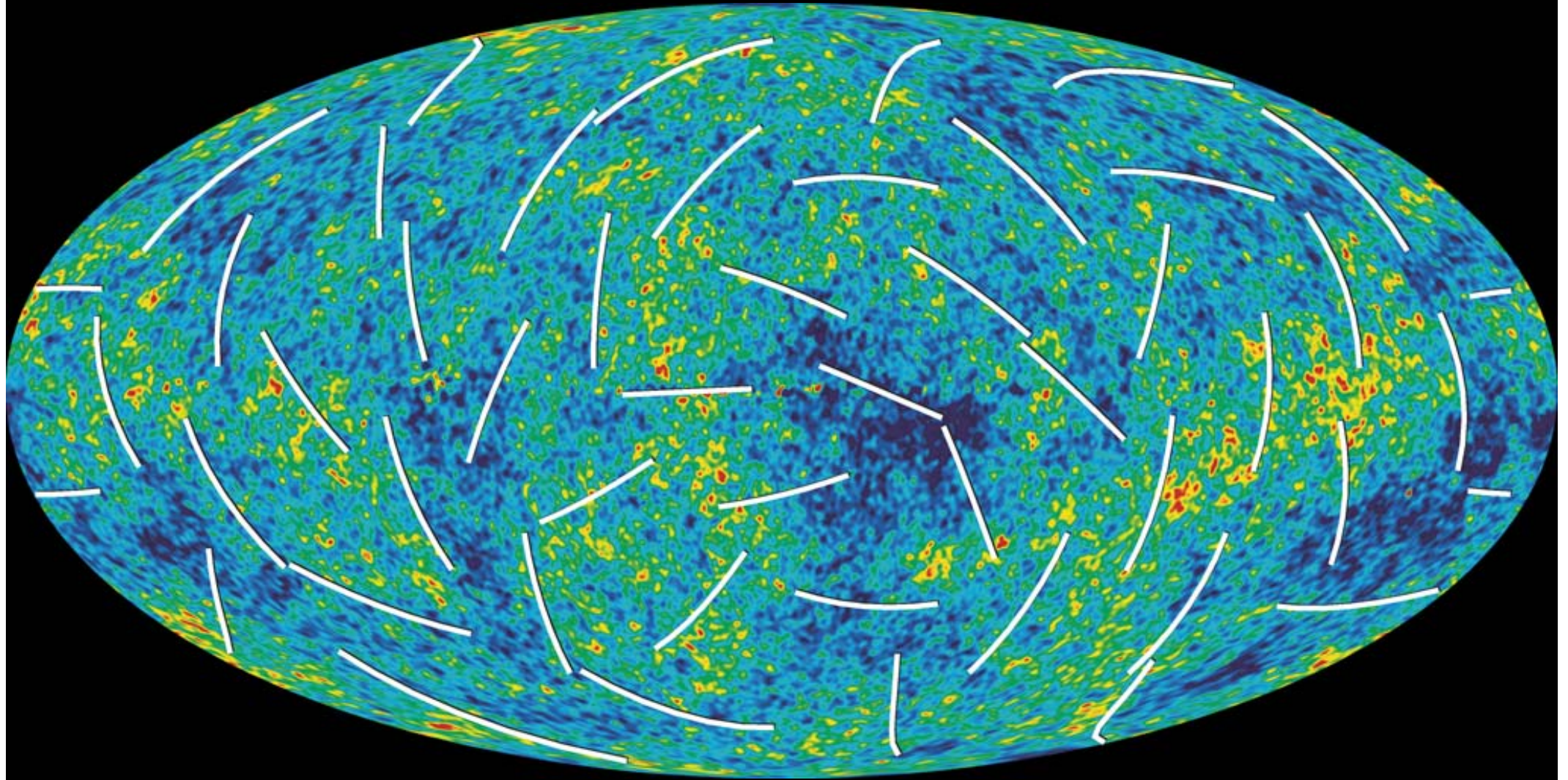

HIGHLIGHTS

- + Full sky polarisation measurements
 - Galactic foregrounds knowledge
 - Simple synchrotron emission model works well
- + Minimal model - power-law CDM - with 6 parameters still fits well.
- + $\chi^2_{\text{eff}}(\text{TT})/\text{dof} = 1.068$ (1.09 yr⁻¹) & $\chi^2_{\text{eff}}(\text{all})/\text{dof} = 1.04$ (1.04 yr⁻¹)
- + Improvements in the constraints on parameters $\{\Omega_b h^2, \Omega_m h^2, h, \tau, n_s, A_s\}$
 - lower σ_8 and Ω_m (\Rightarrow tension with lensing & L_{y_a}),
 - lower n_s and τ (\Rightarrow hint on inflation, removes tension with Galaxy formation)
- + Results from much more sophisticated data analysis

1 YEAR VERSUS 3 YEARS COMPARISON

- + Data smoothed to 1° resolution, scaled to $\pm 200 \mu\text{K}$
- + The difference maps (right) degraded to pixel resolution 4 ($\sim 3.7^\circ$) & scaled to $\pm 20 \mu\text{K}$.
- + Small difference in low- l power, mostly due to improvements in the gain model vs. t

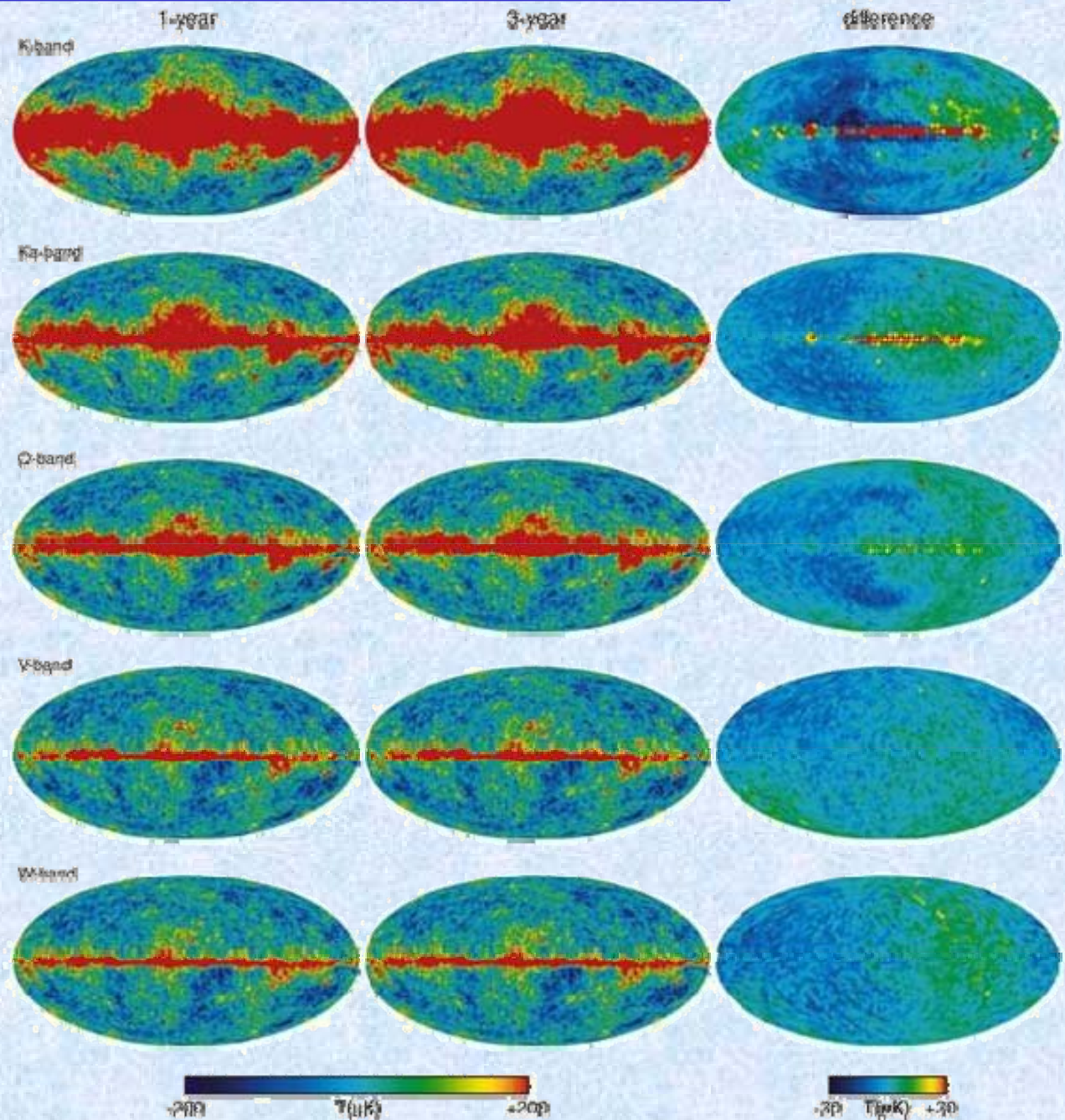

WMAP 1 > WMAP 3

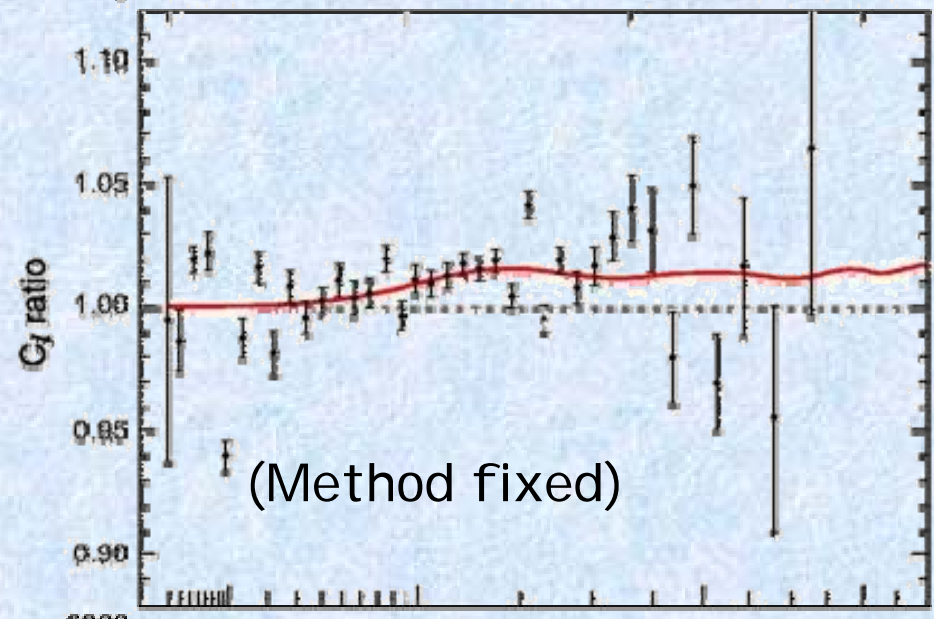
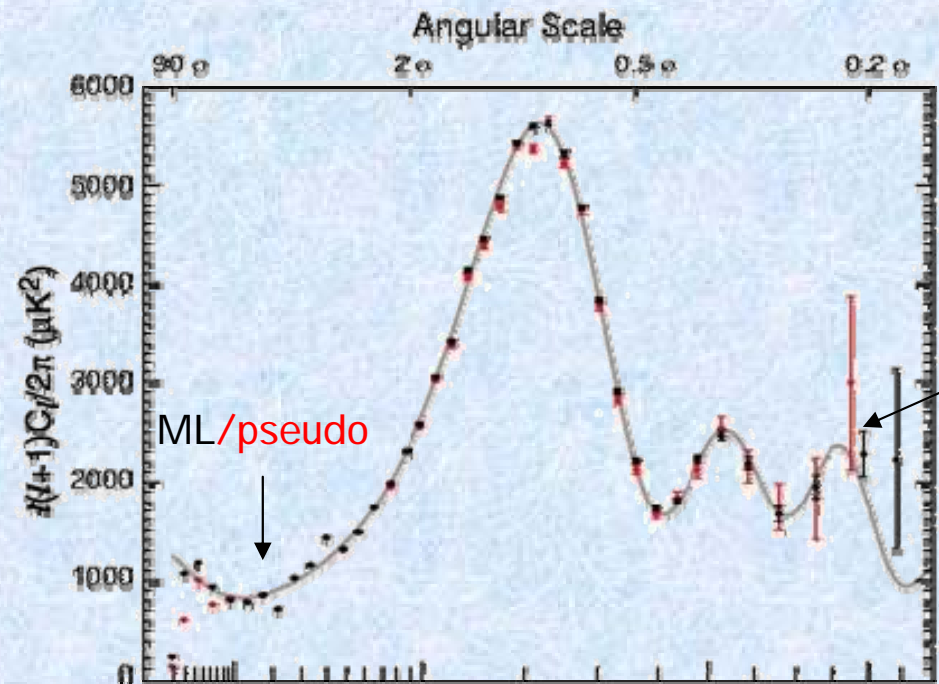
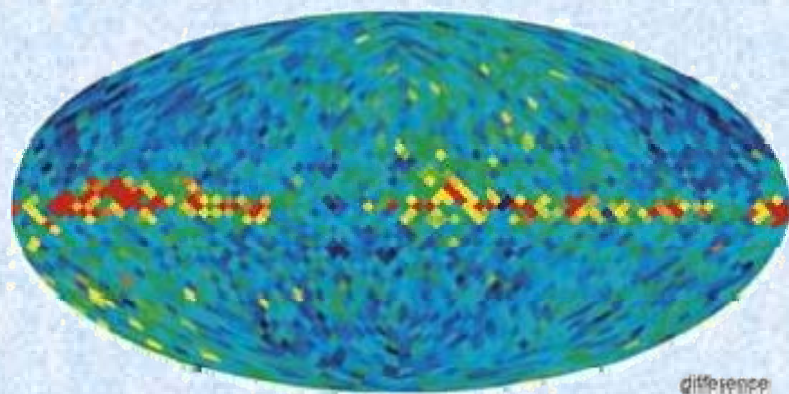
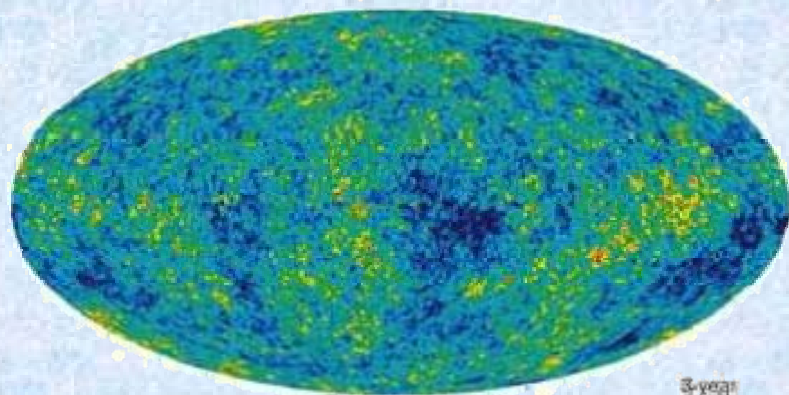
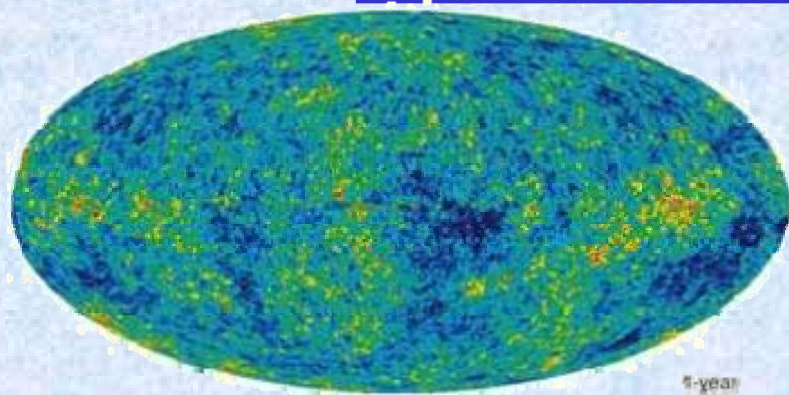

LOW QUADRUPOLE POWER

- + Expected (mean) values for selected best-fit LCDM models -
 - Pure power-law, WMAP+CBI+ACBAR: 1221 mK^{2*}
 - Running index, WMAP+CBI+ACBAR: 870 mK²
 - Power-law, CMB+2dF+Ly- α : 1107 mK²
- + Measured value(s) of quadrupole -
 - Quadratic estimator, V+W band, galaxy template & cut: 123 mK²
(Hinshaw, et al., ApJS, 148, 135, 2003)
 - Full-sky estimate, Galaxy-cleaned map: 184 mK²
(Tegmark et al, astro-ph/0302496)
 - Full-sky estimate, Linear Combination map: 154 \pm 70 mK²
Error based on spread of values by galaxy cut and frequency
(Bennett, et al., ApJS, 148, 1, 2003)
 - Max. likelihood estimate, Galaxy-cleaned map(s): 176-250 mK²
(Efstathiou, astro-ph/0310207)
 - Max. likelihood estimate, Galaxy template marginalization: < 300 mK²
(Bielewicz, astro-ph/0405007; Slosar & Seljak, astro-ph/04??)
- + Likelihood of low quadrupole given power-law LCDM model -
~2% - 10%
- + Fine print: estimates of significance depend on
 - 1) quadrupole estimation method,
 - 2) handling of foreground errors,
 - 3) handling of cosmic variance errors,
 - 4) handling of cosmological parameter errors.

LOW- l (NEW, ML) ANALYSIS

- Black= posterior distribution of $l(l+1)Cl/2\pi$ from the I LC map outside the Kp2 sky cut
- Vertical red = Mean for best fit CDM to WMAP
- Purple=pseudo- $C(l)$ estimate, tend to be lower than peak at $l = 2, 3, 7$
- Quadrupole still rather low, but now the only one*
- NB: Vertical black dot-dash = maximum with no sky cut; orange – with Kp2 V-band only

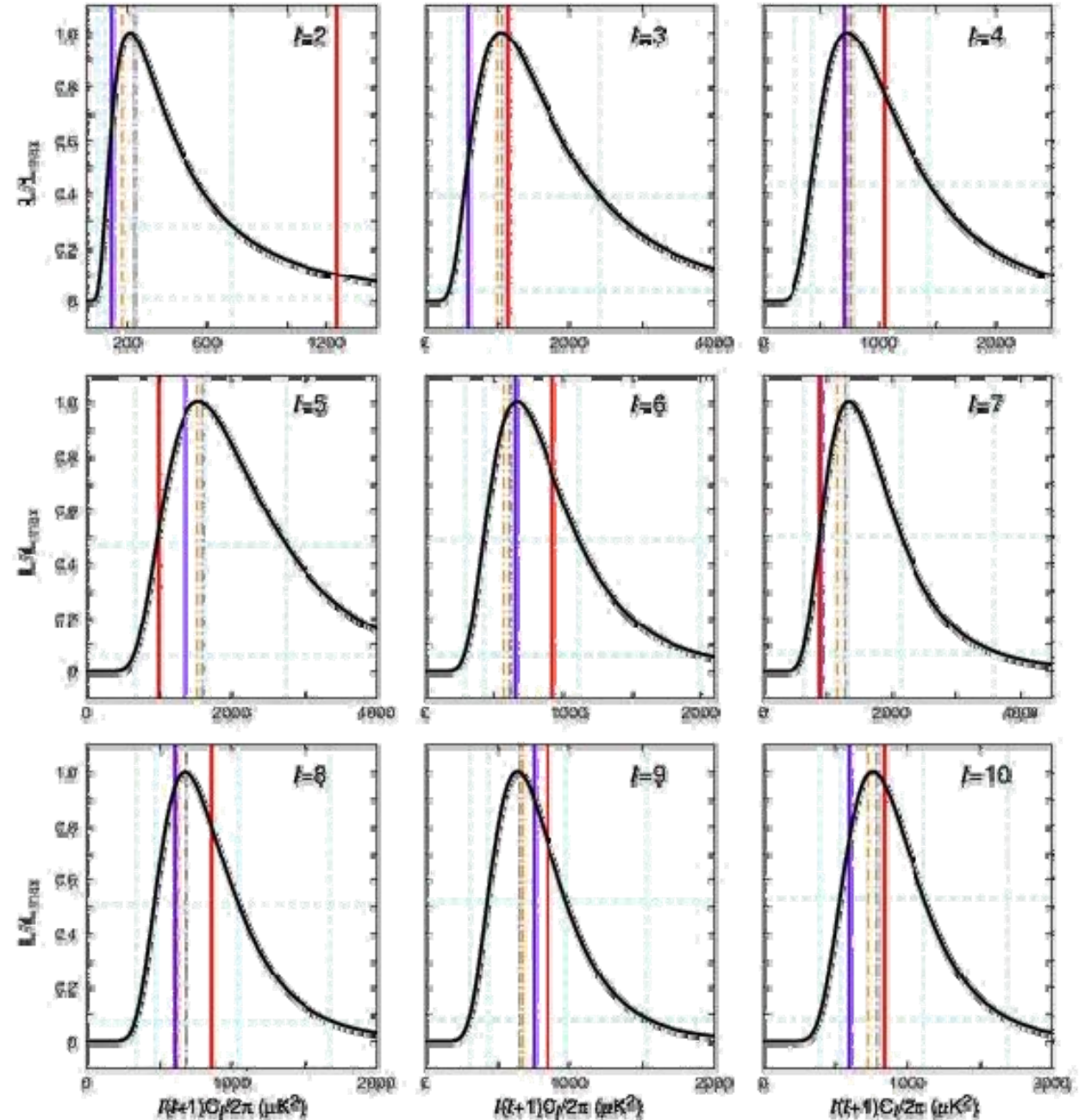

“LOOKS” OK?

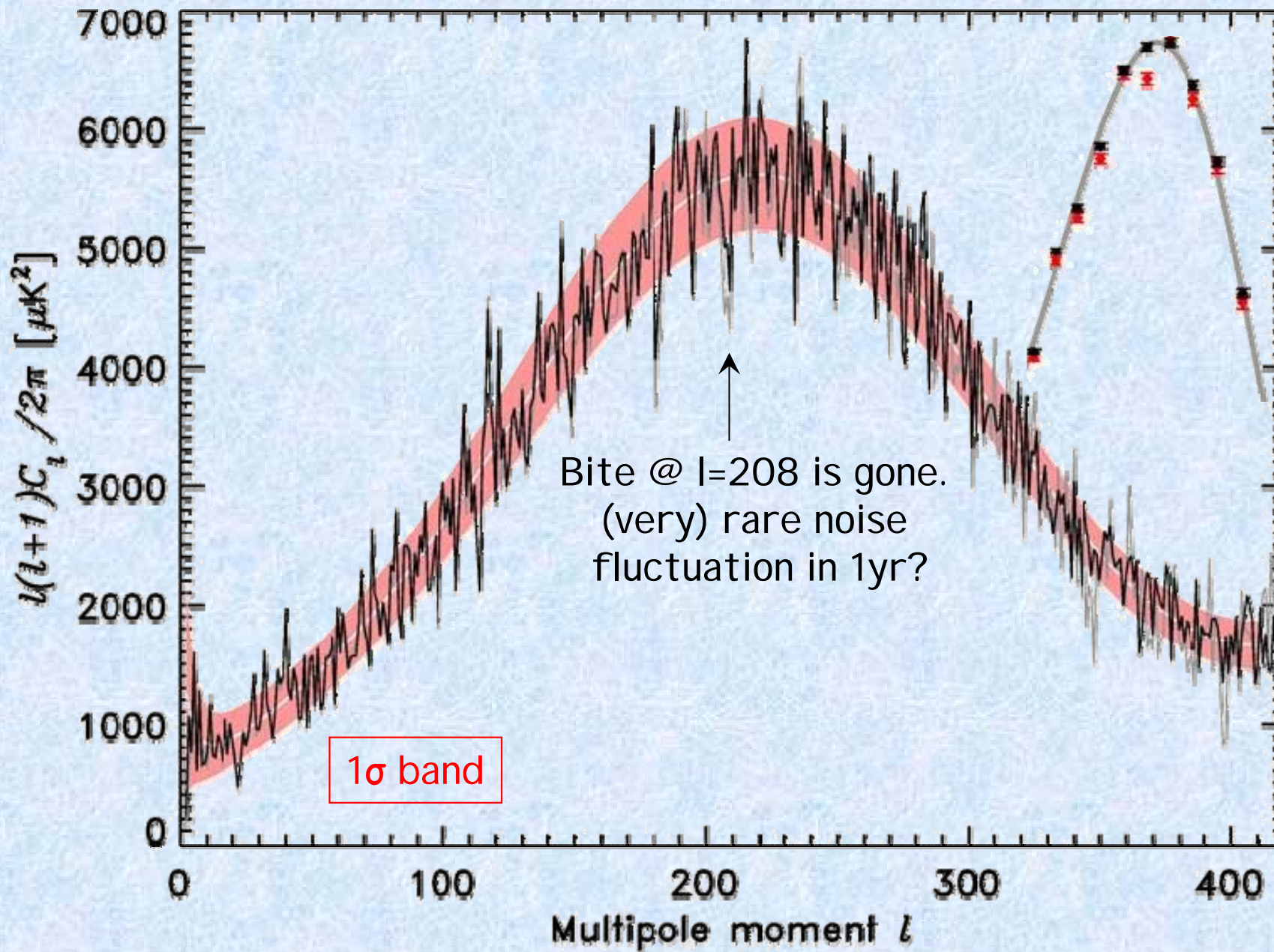

SUMMARY OF IMPROVEMENTS IN THE POLARIZATION ANALYSIS

First Year (TE)

- + Foreground Removal
 - Done in harmonic space
- + Null Tests
 - Only TB
- + Data Combination
 - Ka, Q, V, W are used
- + Data Weighting
 - Diagonal weighting
- + Likelihood Form
 - Gaussian for C_l
 - C_l estimated by MASTER

Three Years (TE,EE,BB)

- + Foreground Removal
 - Done in pixel space
- + Null Tests
 - 1 Year Difference & TB, EB, BB
- + Data Combination
 - Only Q and V are used
- + Data Weighting
 - Optimal weighting (C-1)
- + Likelihood Form
 - Gaussian for the pixel data
 - C_l not used at $l < 23$

These are improvements only in the analysis techniques: there are also various improvements in the polarization map-making algorithm. See Jarosik et al. (2006)

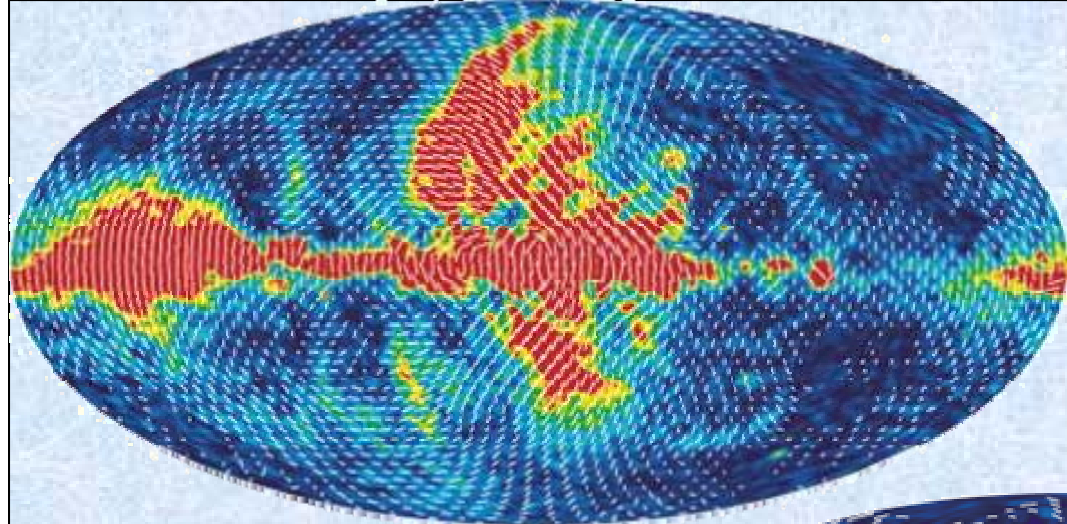

K 23GHz

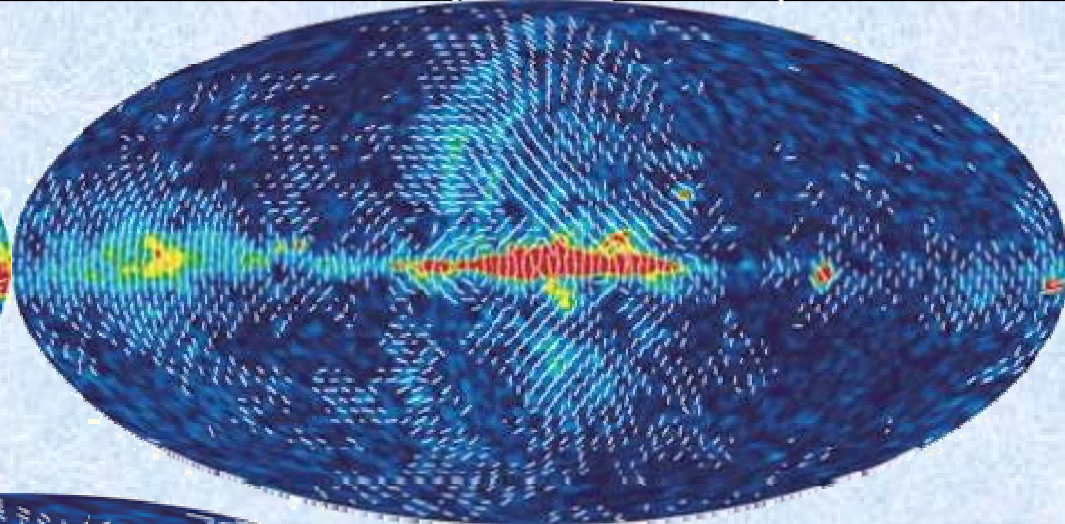
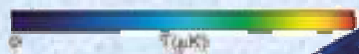

Ka-33GHz



Color: polarization Intensity,
smoothed to 2° FWHM
 $P = (Q^2 + U^2)^{1/2}$

Direction: shown for S/N>1

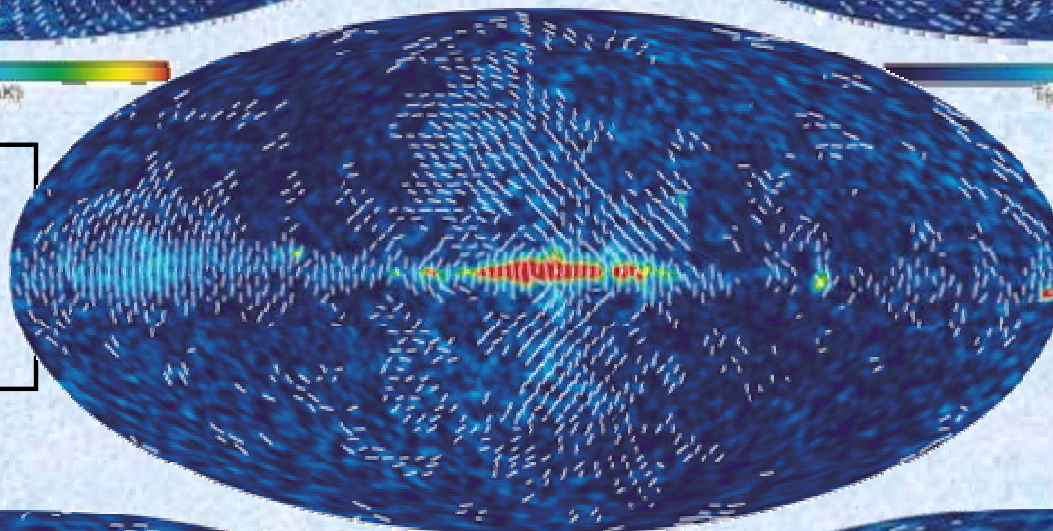

Q-41GHz



V-61GHz

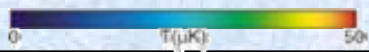
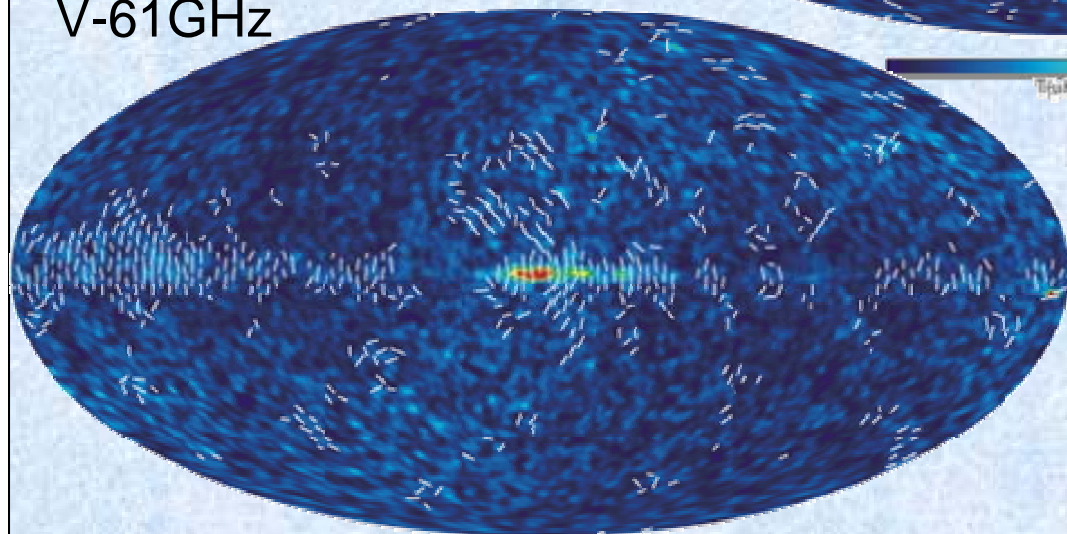

W-94GHz

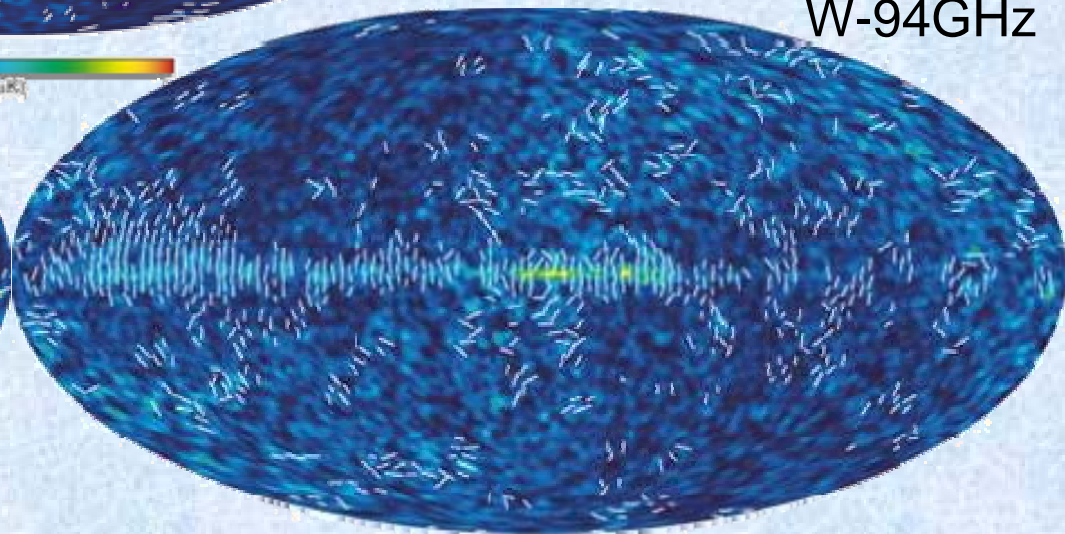

POLARISED FOREGROUNDS (OUTSIDE P06)

- ✚ EE Solid
- ✚ BB Dashed
- ✚ Frequency = geometric mean of data used for the spectra
- ✚ Red = estimate of FG level for BB at 60 GHz
- ✚ High- l rise \leftrightarrow noise

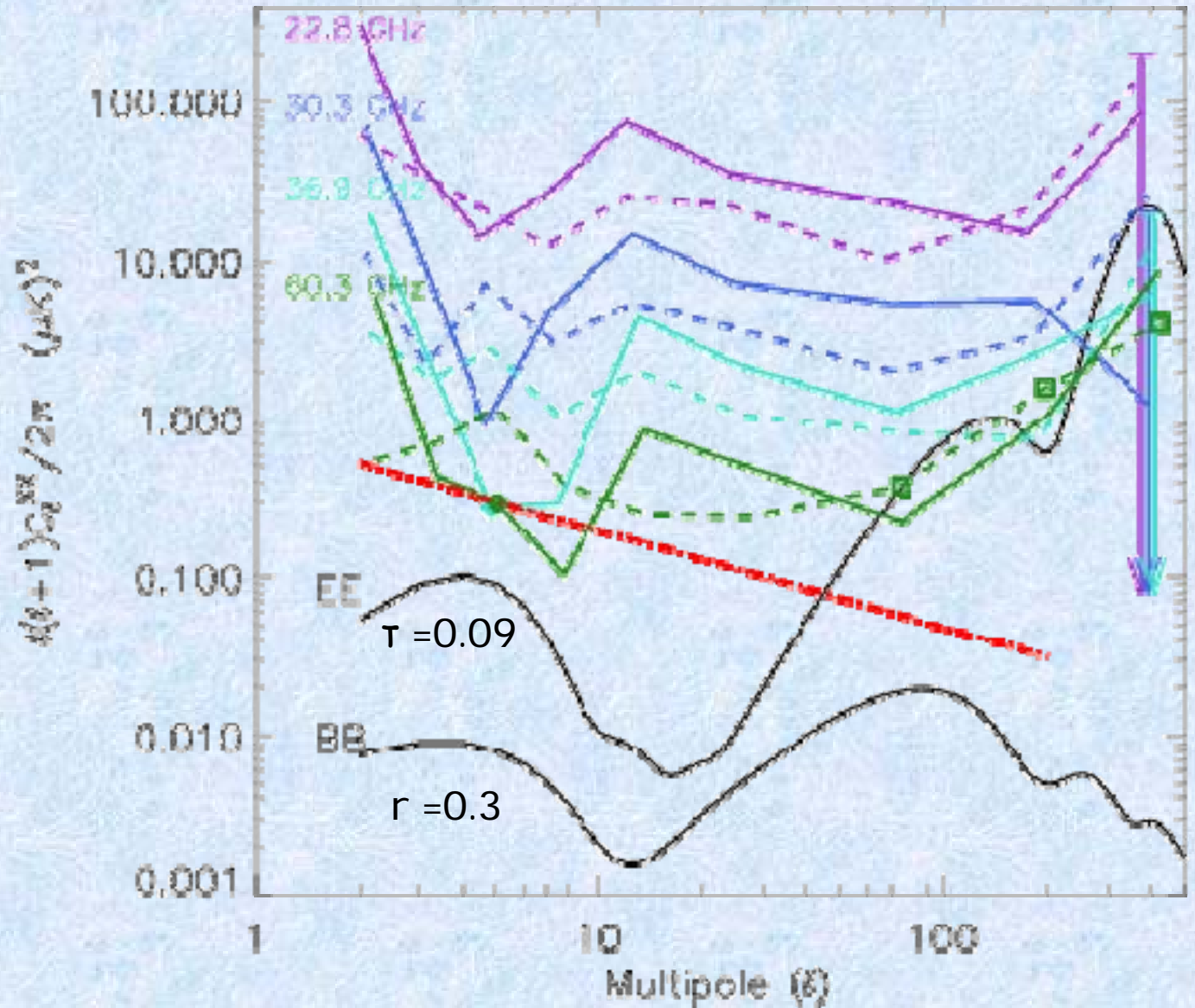

MUST BE CLEANED...

SYNCHROTRON EMISSION

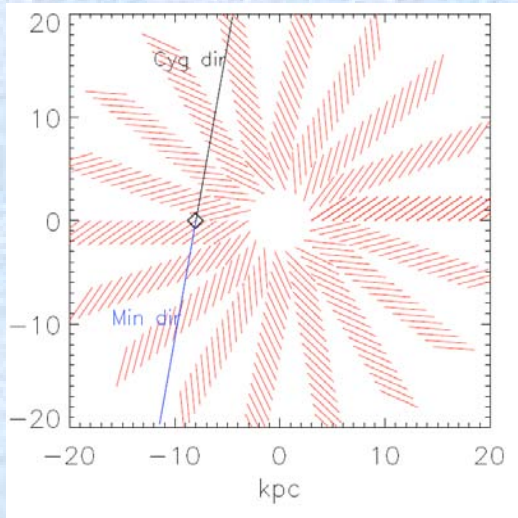

Bisymmetric Spiral
Magnetic Field Model
+ electron distribution:
 $n_e = n_0 \exp(-r/5) \sec^2(z)$

Rotation angle

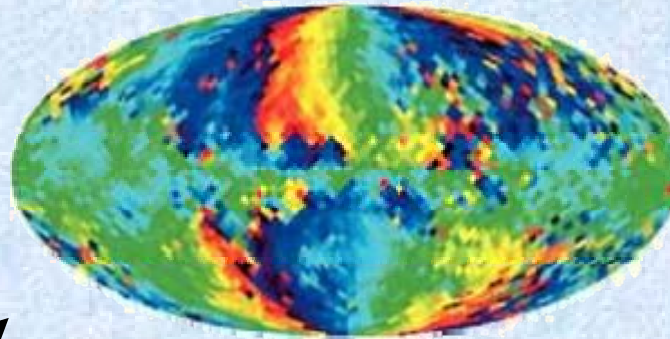

B field from K band

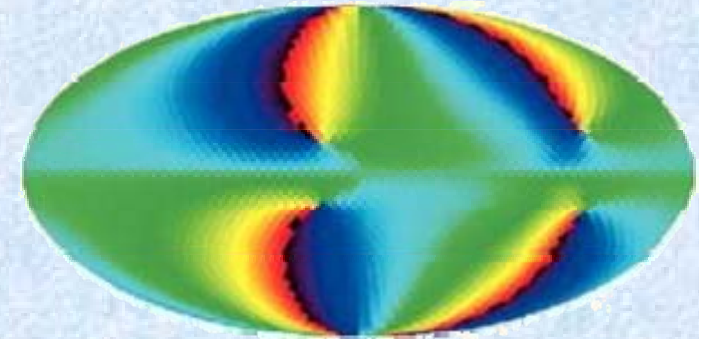

B field from model

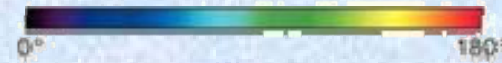

Polarisation amplitude

K1 Polarization Amplitude

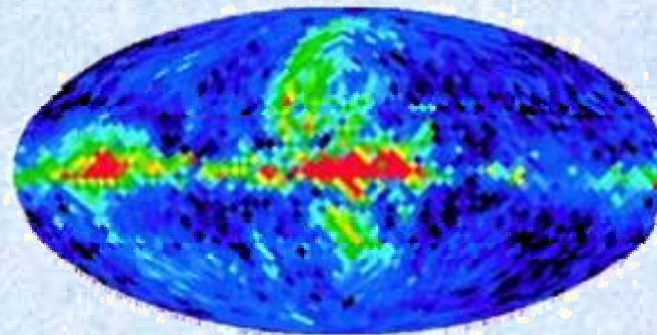

Observed P@23GHz

K1 Polarization Prediction from Haslam

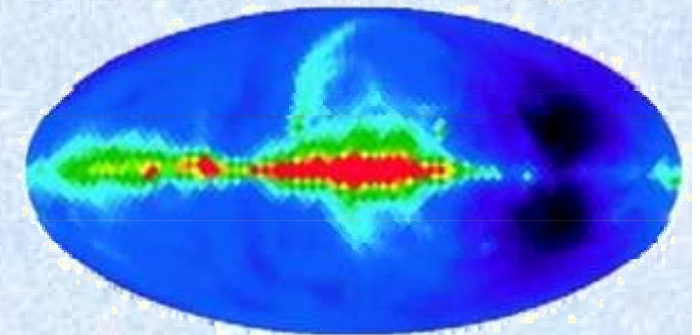

Predicted P@23GHz

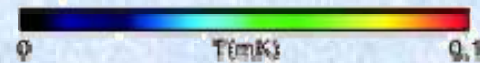

EXPECT PROGRESS IN DUST MODELLING

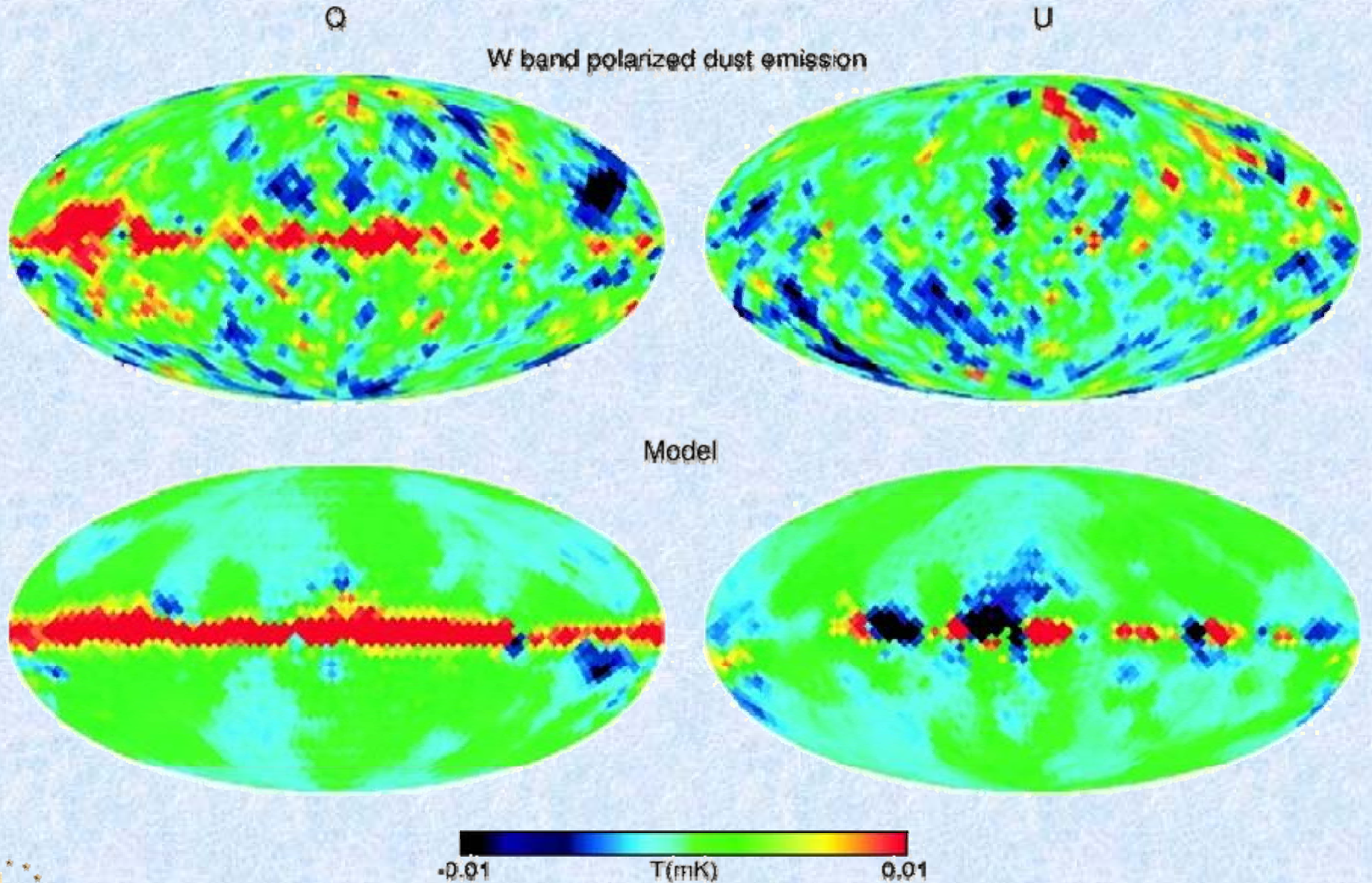

POLARISED FOREGROUNDS SUBTRACTION

- Fit & subtract 2 spatial templates of Galactic emission (Q is shown)
- Synchrotron: 23 GHz
Q & U
- Dust: Intensity
COBE/IRAS-FDS plus
Sparse polarisation
angle data from
starlight absorption

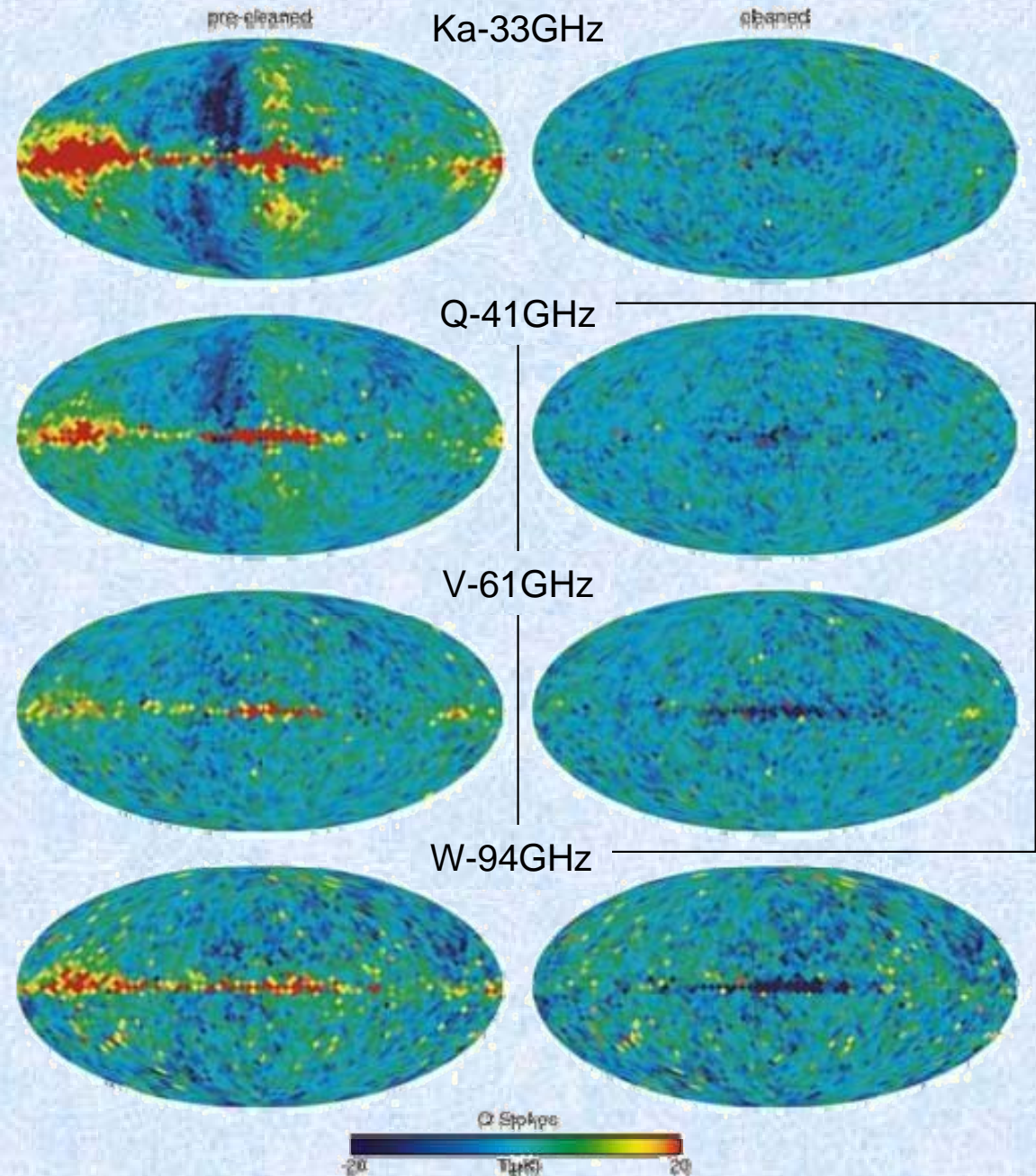

LOW-L POLARISATION SPECTRA

EE

BB

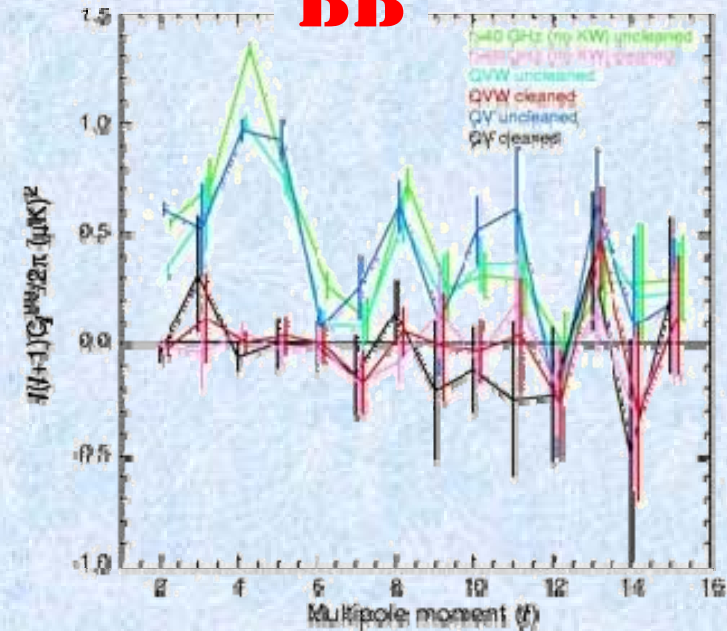
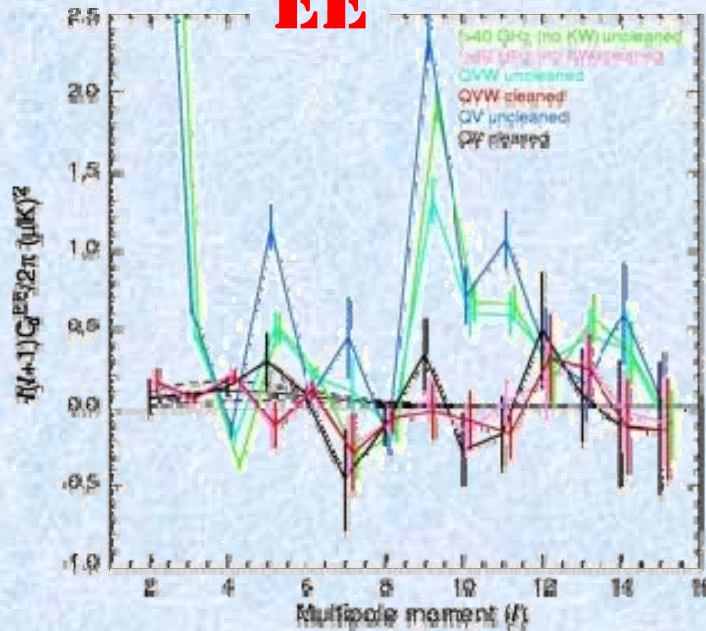

What the cleaning does...

About all reionisation information comes from that bump...

$$l^2 C^{E<2-6>}/2\pi = 0.09 \pm 0.03 \mu\text{K}^2$$

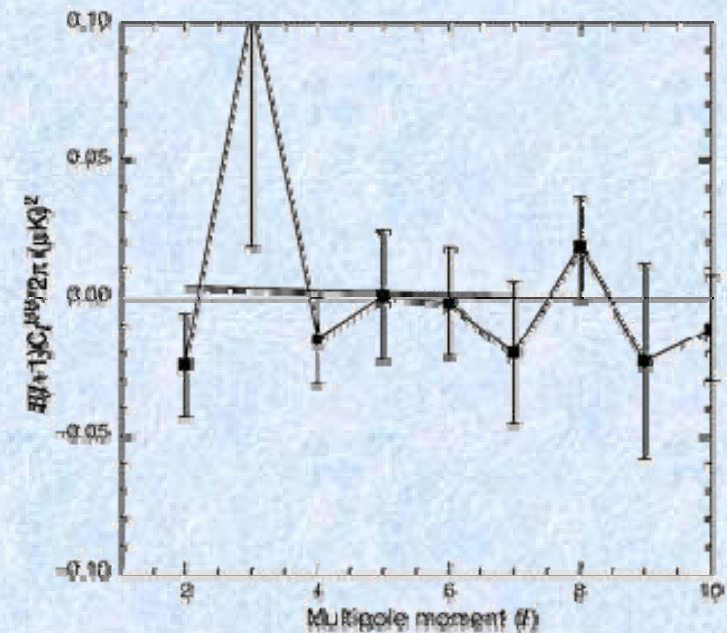
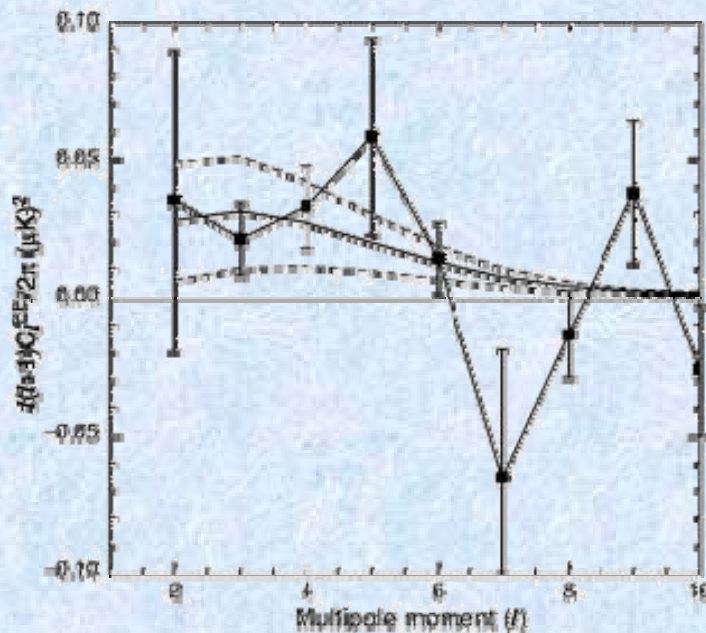

PREDICTED C(L) ERRORS (IN μK^4)

variations in the N^{-1} weighting are due to the scan pattern combined with the sky cut.

W data 3 years still not good enough at $l=5, 7$!

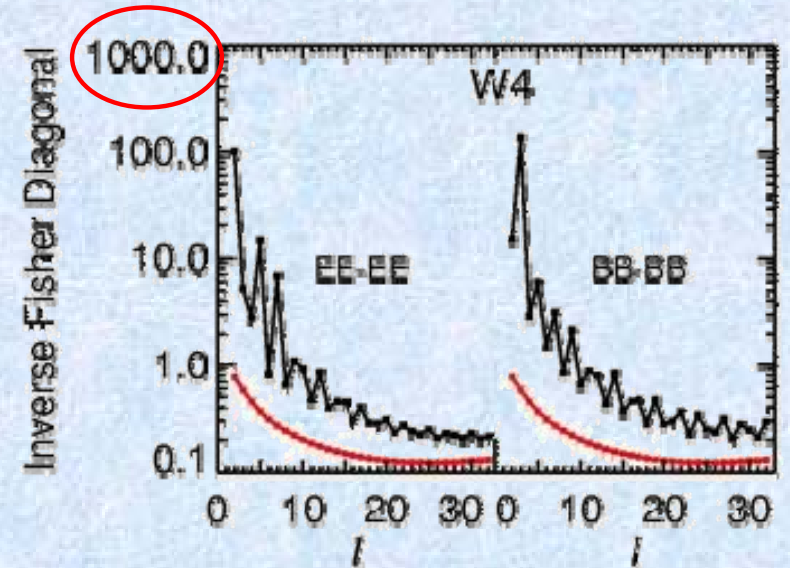
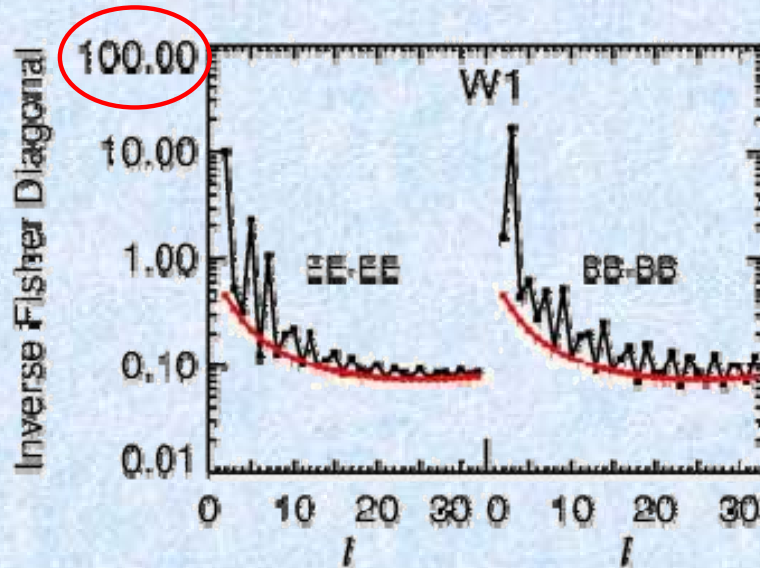
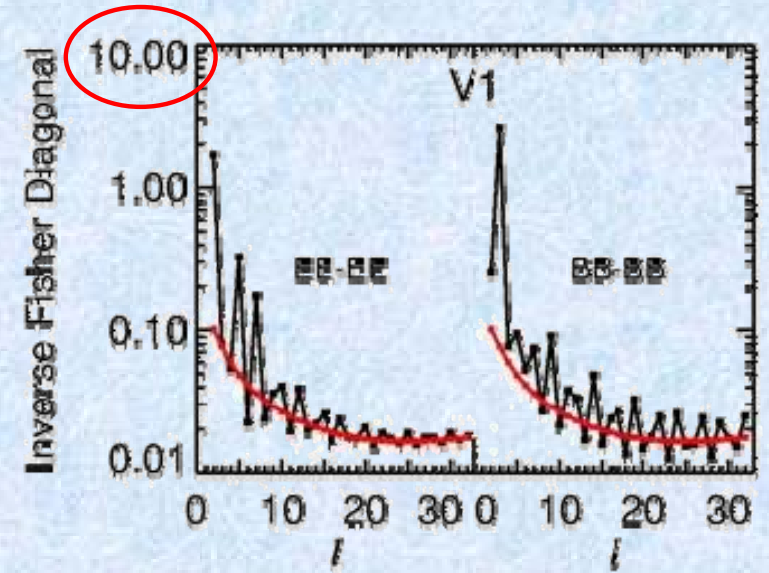
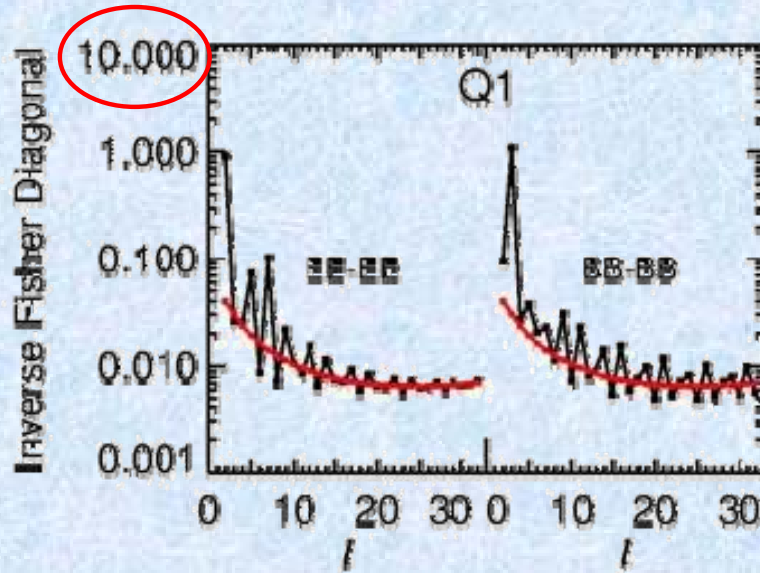

WMAP3 SPECTRA

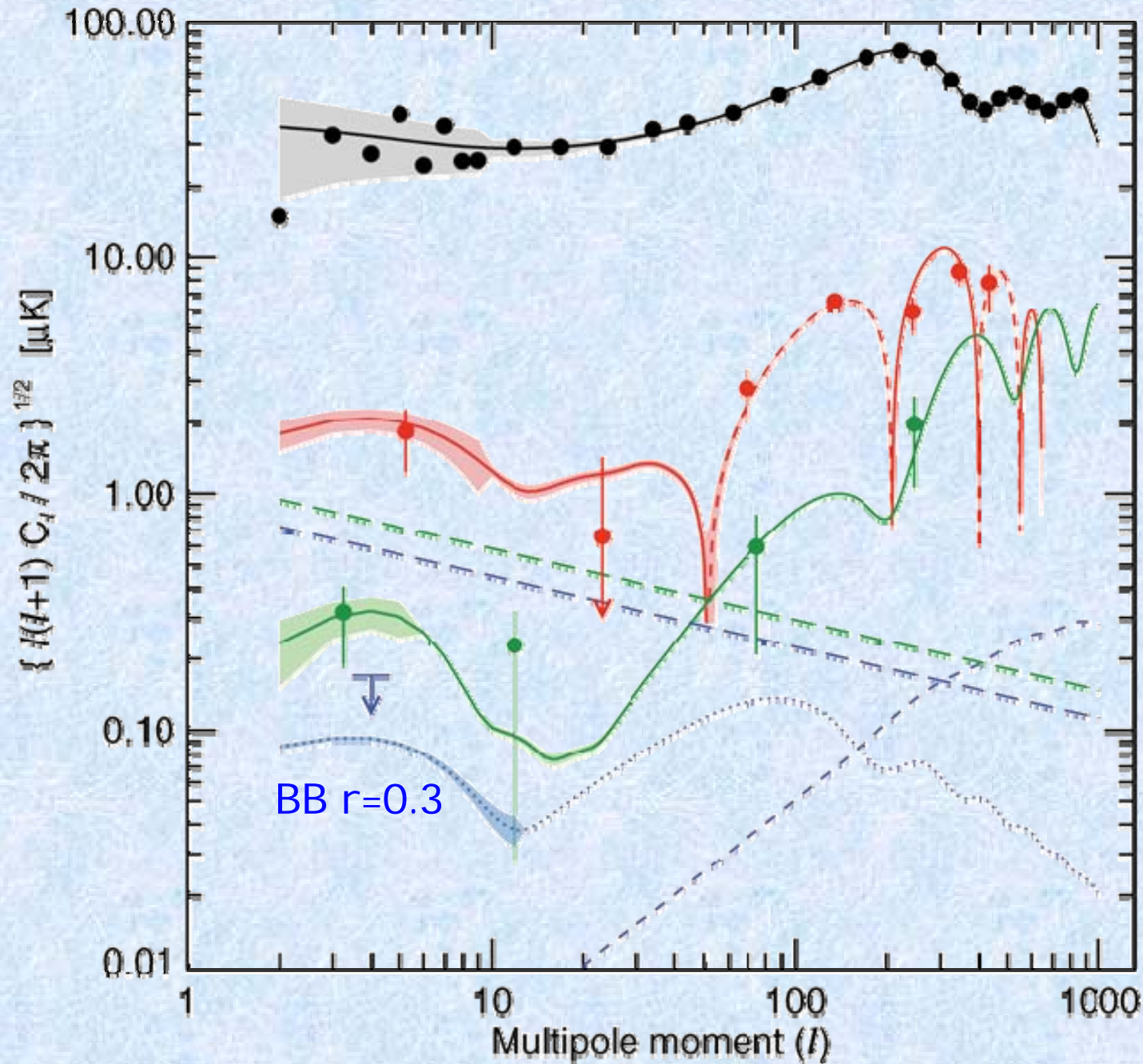

Approx EE/BB
foreground

EE SPECTRUM AT $\ell > 40$ (ALL TODAY)

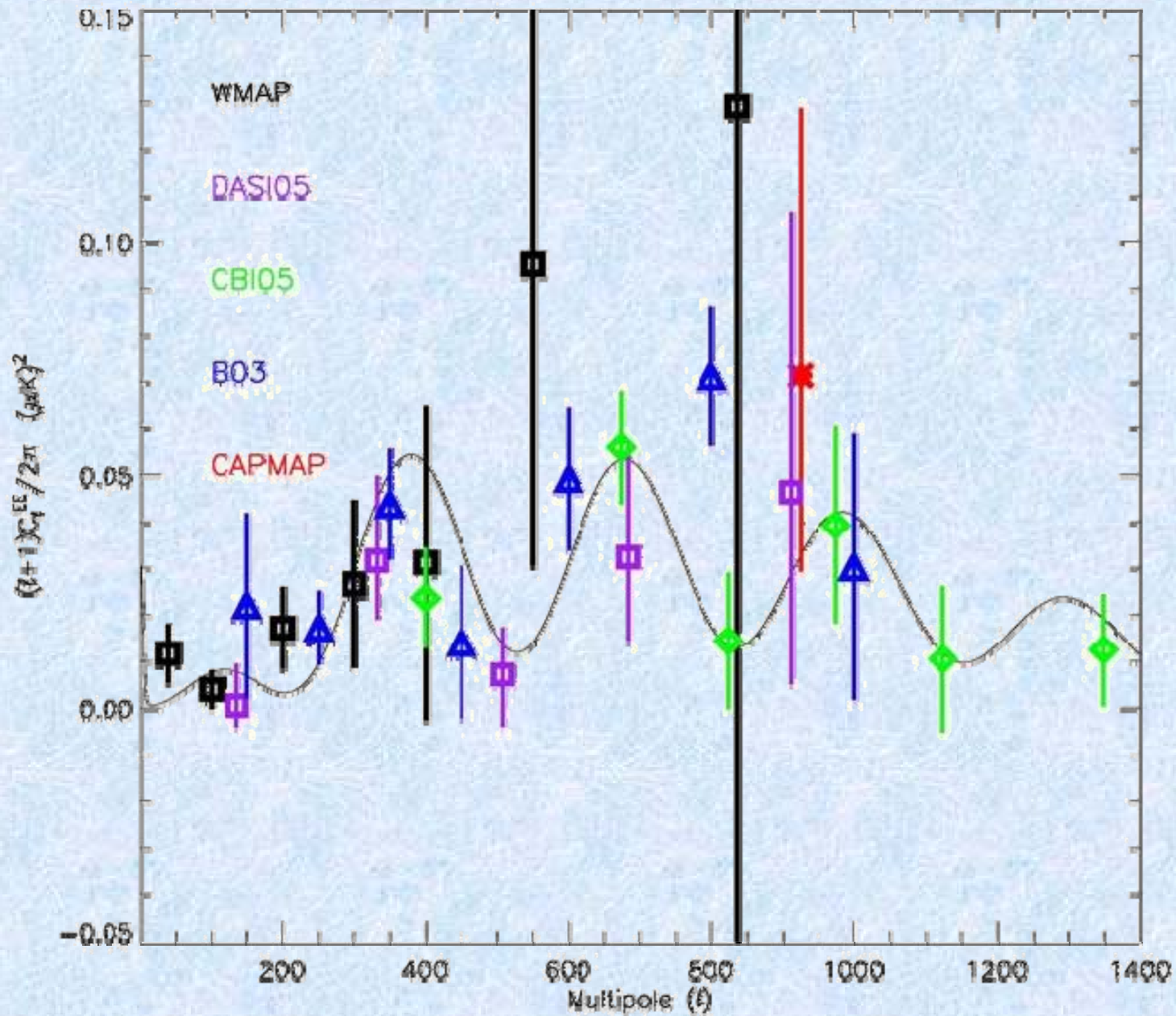

3 YEARS RESULTS

WMAP3 ONLY/ALL

ALL=WMAP+2dFGRS+SDSS+ACBAR+BOOMERanG+CBI +VSA+SN(HST/GOODS)+SN(SNLS)

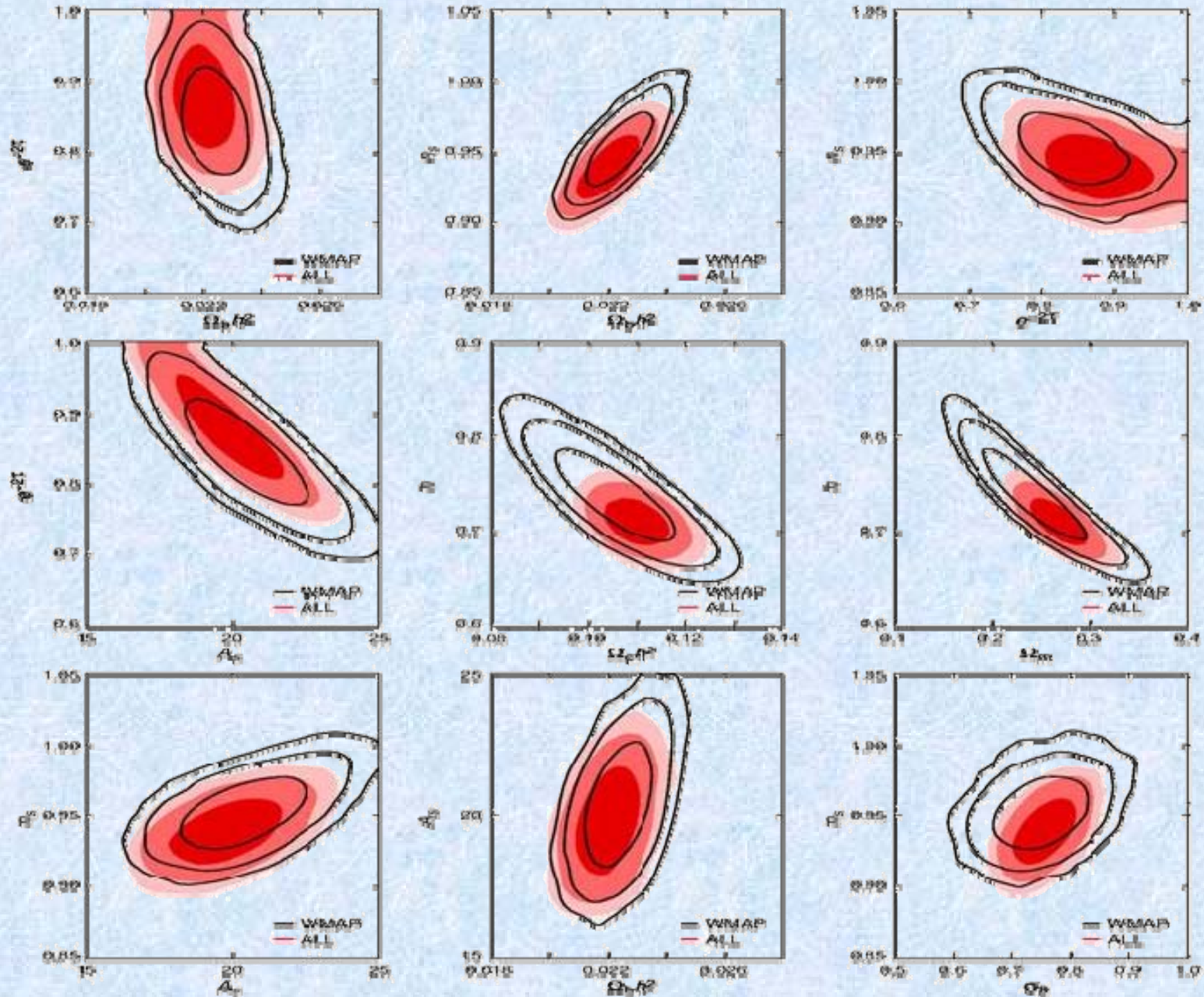

CONSISTENCY WITH LSS

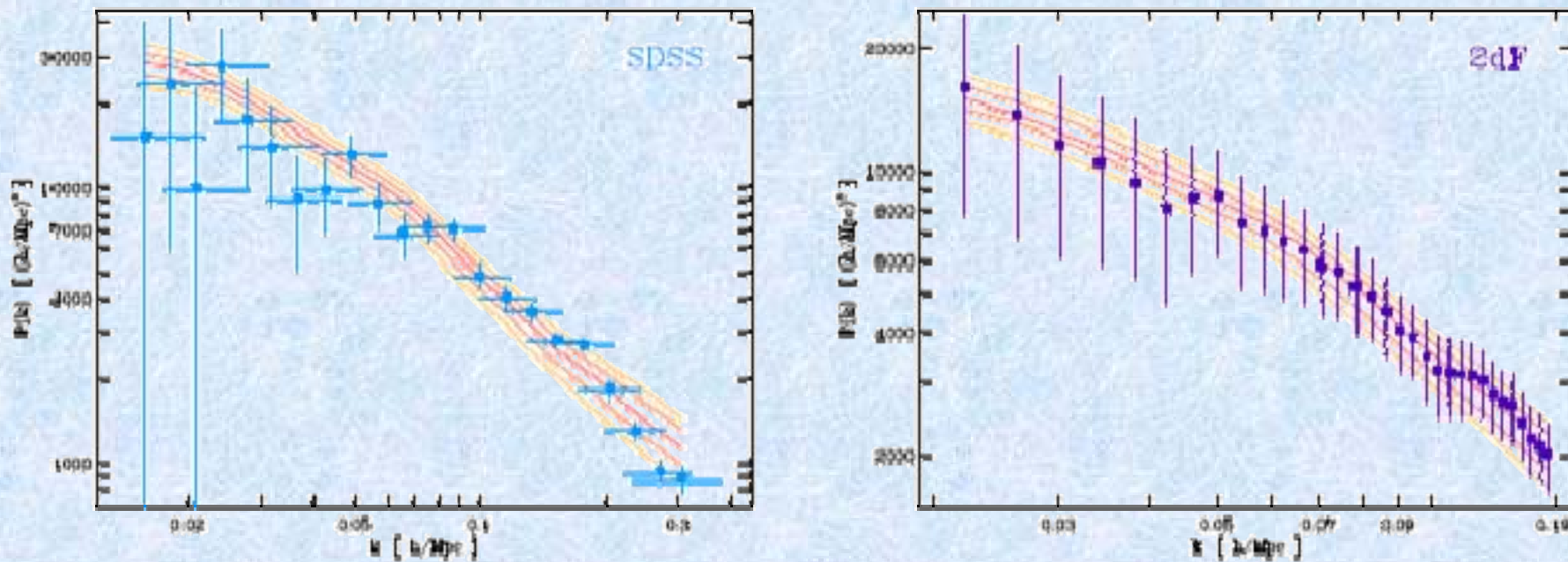
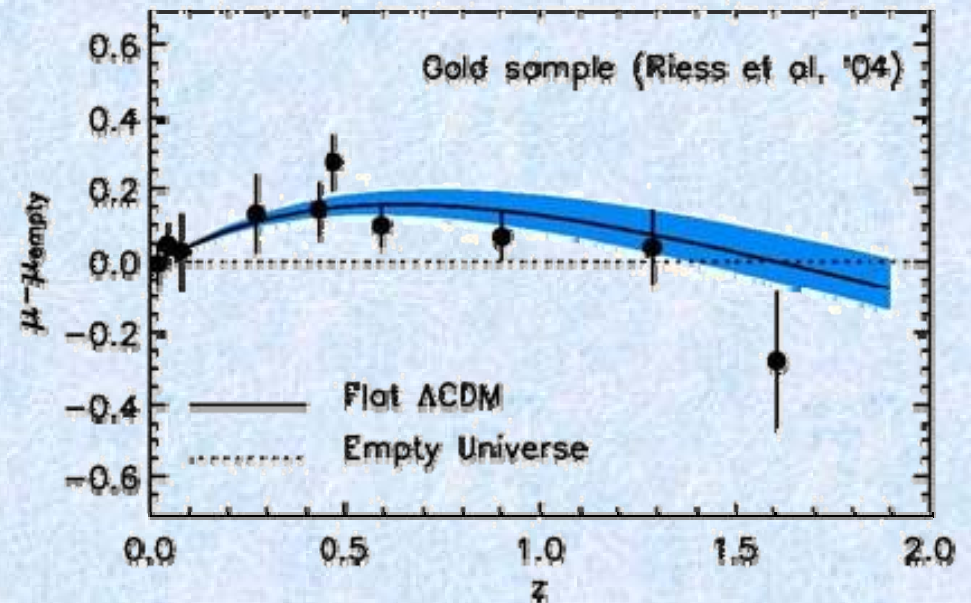
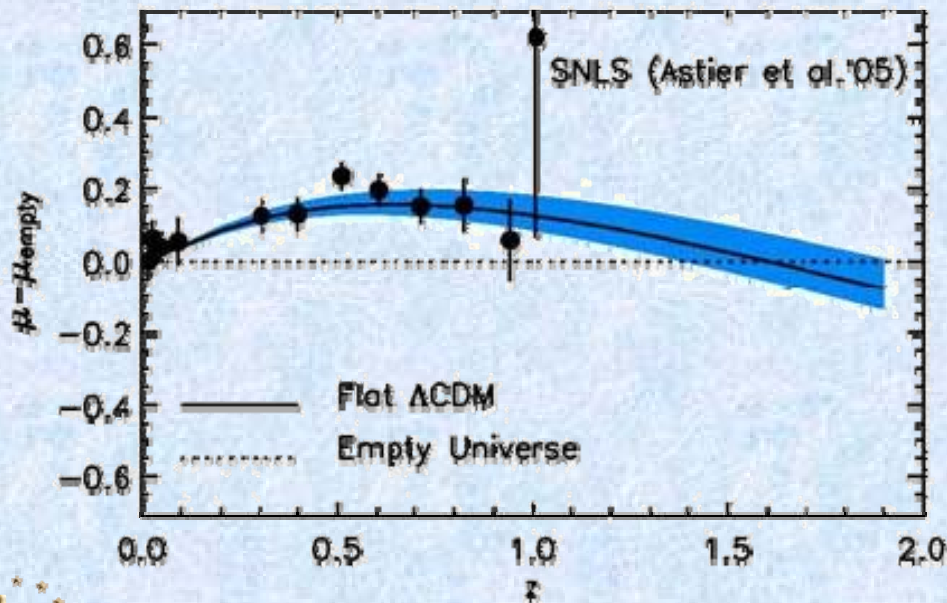
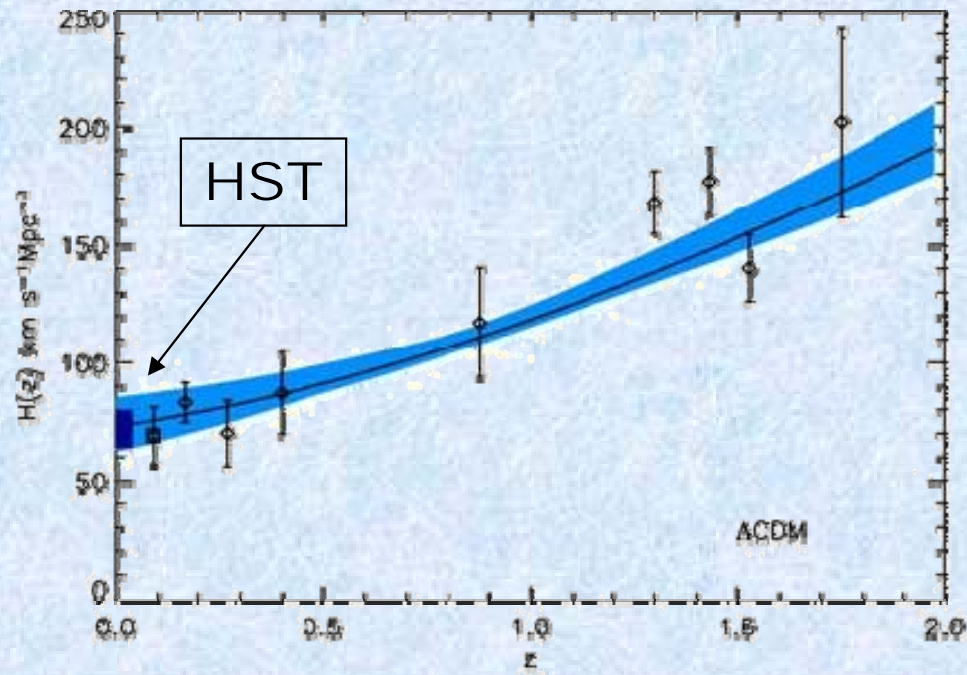
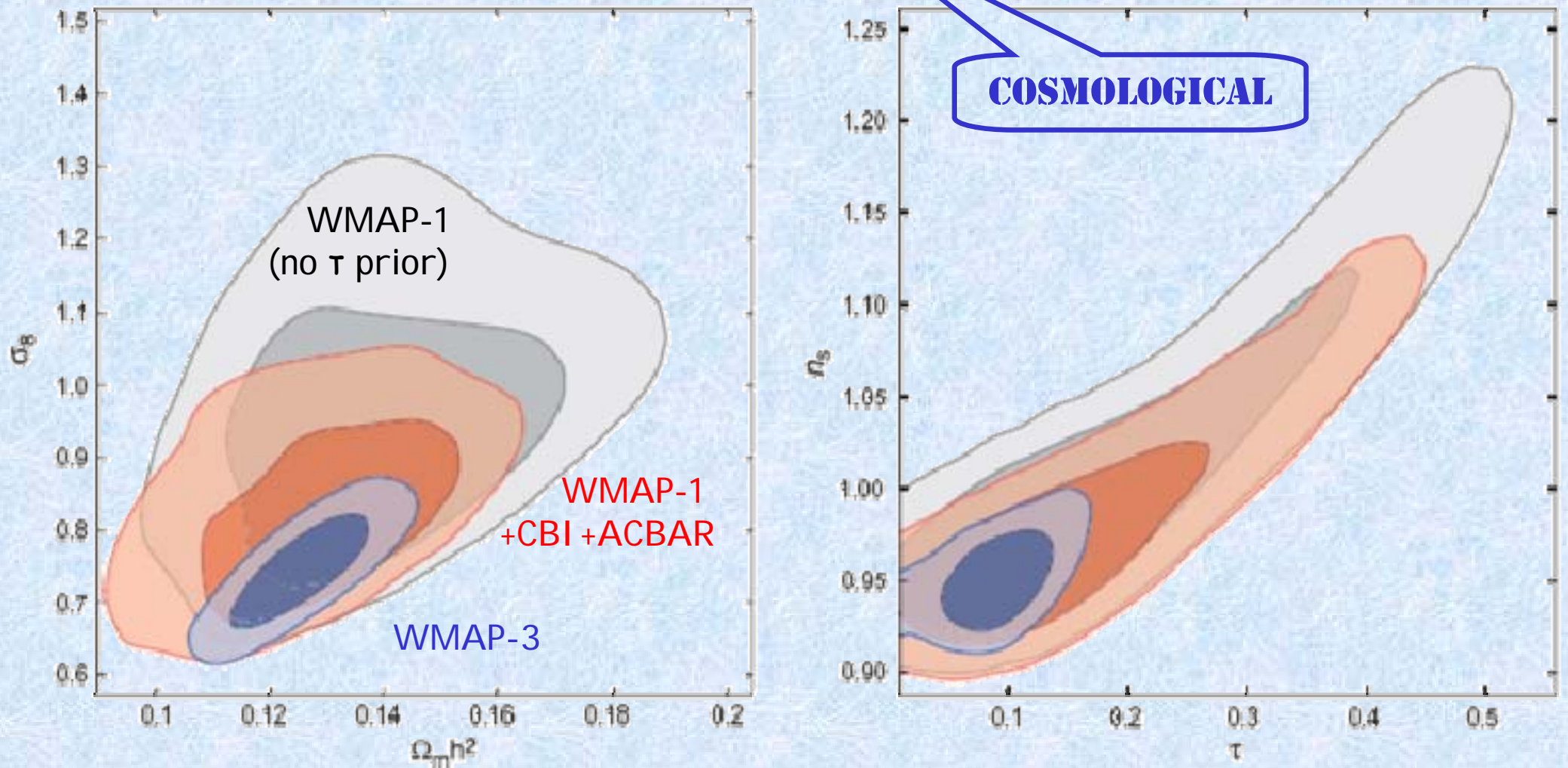

Fig. 6.— The prediction for the mass fluctuations measured by galaxy surveys from the Λ CDM model fit to the WMAP data only. (*Left*) The predicted power spectrum (based on the range of parameters consistent with the WMAP-only parameters) is compared to the mass power spectrum inferred from the SDSS galaxy power spectrum (Tegmark et al. 2004b) and normalized by weak lensing measurements (Seljak et al. 2005b). (*Right*) The predicted power spectrum is compared to the mass power spectrum inferred from the 2dFGRS galaxy power spectrum (Cole et al. 2005) with the best fit value for b_{2dFGRS} based on the fit to the WMAP model. Note that the data points shown are correlated.

FURTHER PREDICTIONS



WMAP MAIN RESULTS



Improvement in parameter constraints for the power-law CDM model (6 pars).

$$\{\Omega_b h^2, \Omega_m h^2, h, \tau, n_s, A_s\}$$

$\chi^2_{\text{eff}} (\text{TT})/\text{dof} = 1.068$ (1.09 yr⁻¹) & $\chi^2_{\text{eff}} (\text{all})/\text{dof} = 1.04$ (1.04 yr⁻¹)

$A_S - \Omega_M$

CMB (WMAP1ext) with galaxy lensing (+BBN prior)

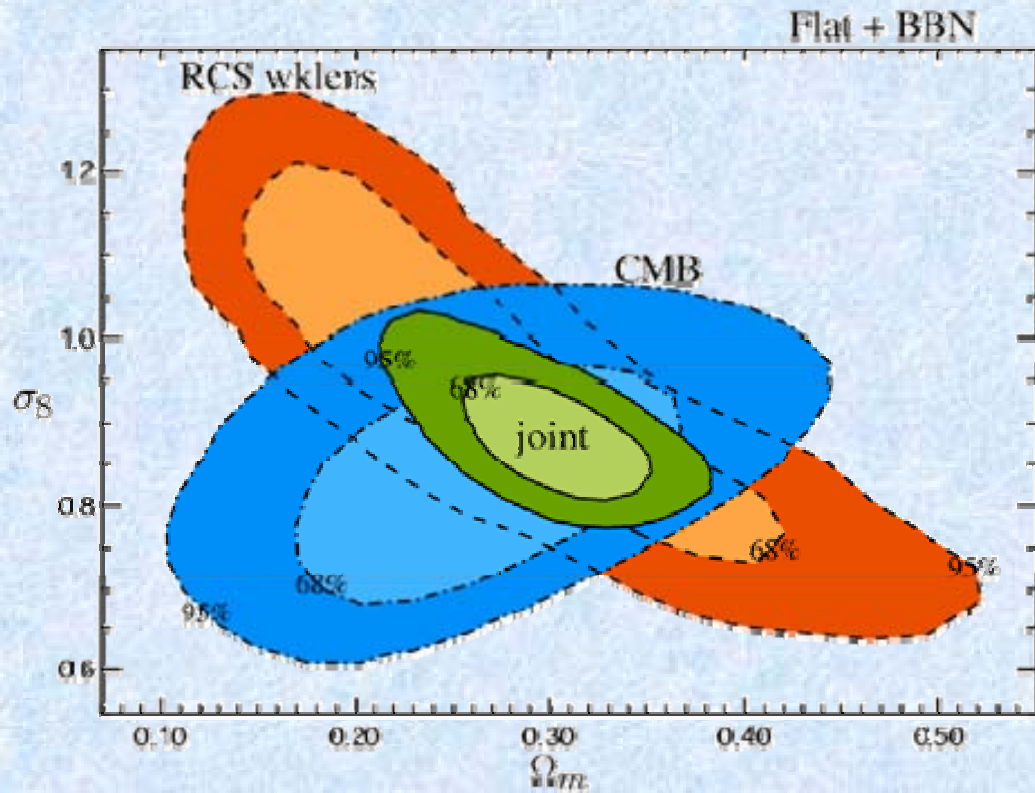

Contaldi, Hoekstra, Lewis: astro-ph/0302435

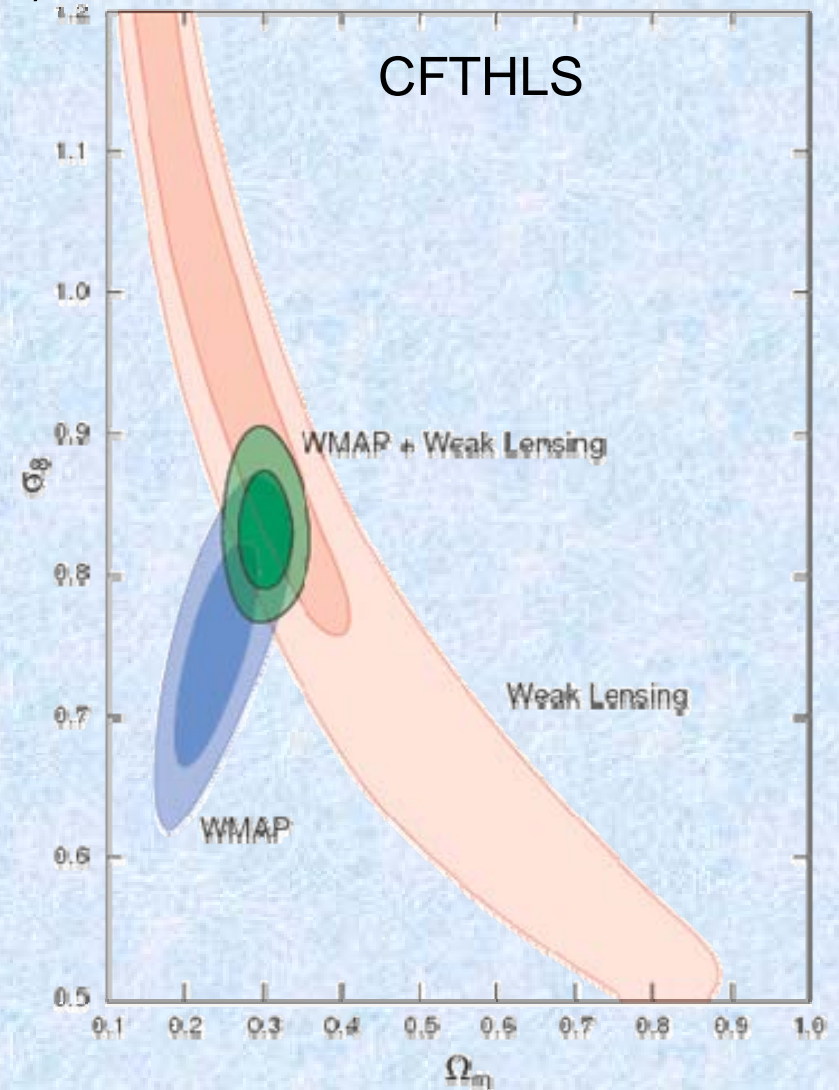

Spergel et al 2006

NB: σ_8 and A_S are just different normalisation of the (scalar) power spectrum

LYMAN ALPHA + WMAP

WMAP 1

WMAP 3

bfp: $n_s=0.97$, $s_8=0.88$

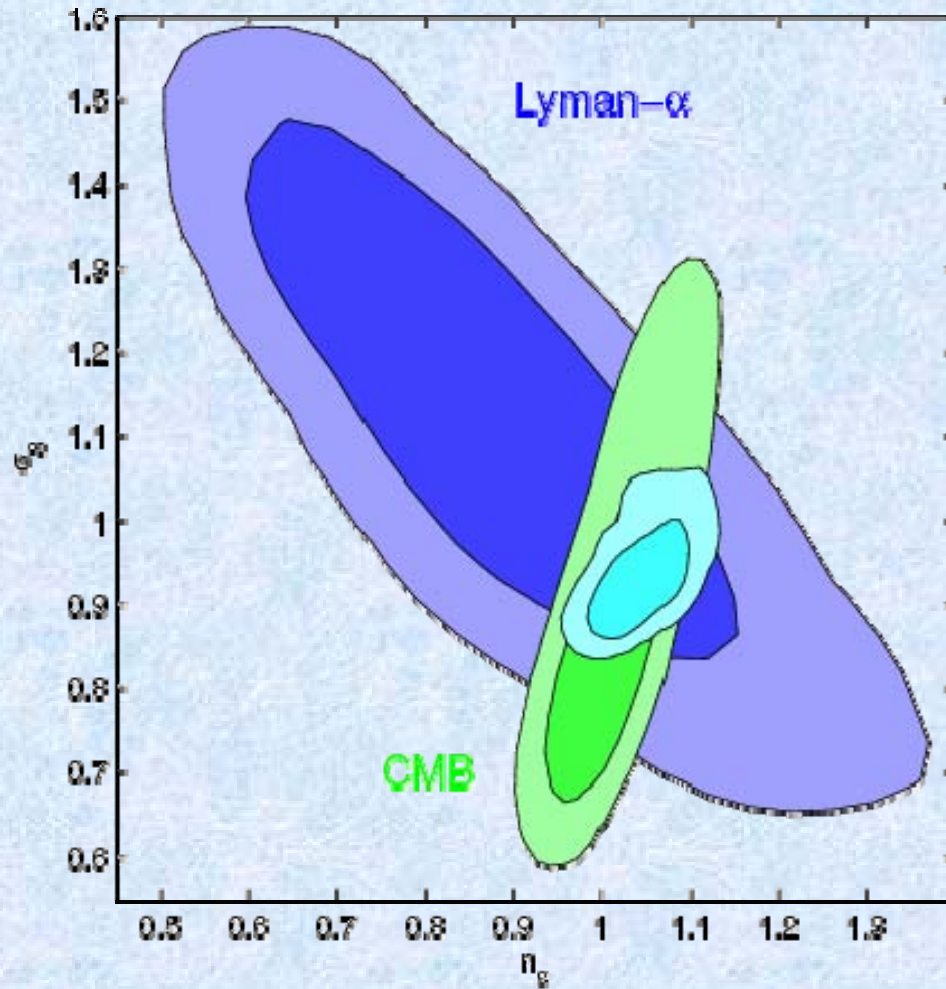

(both +HST)

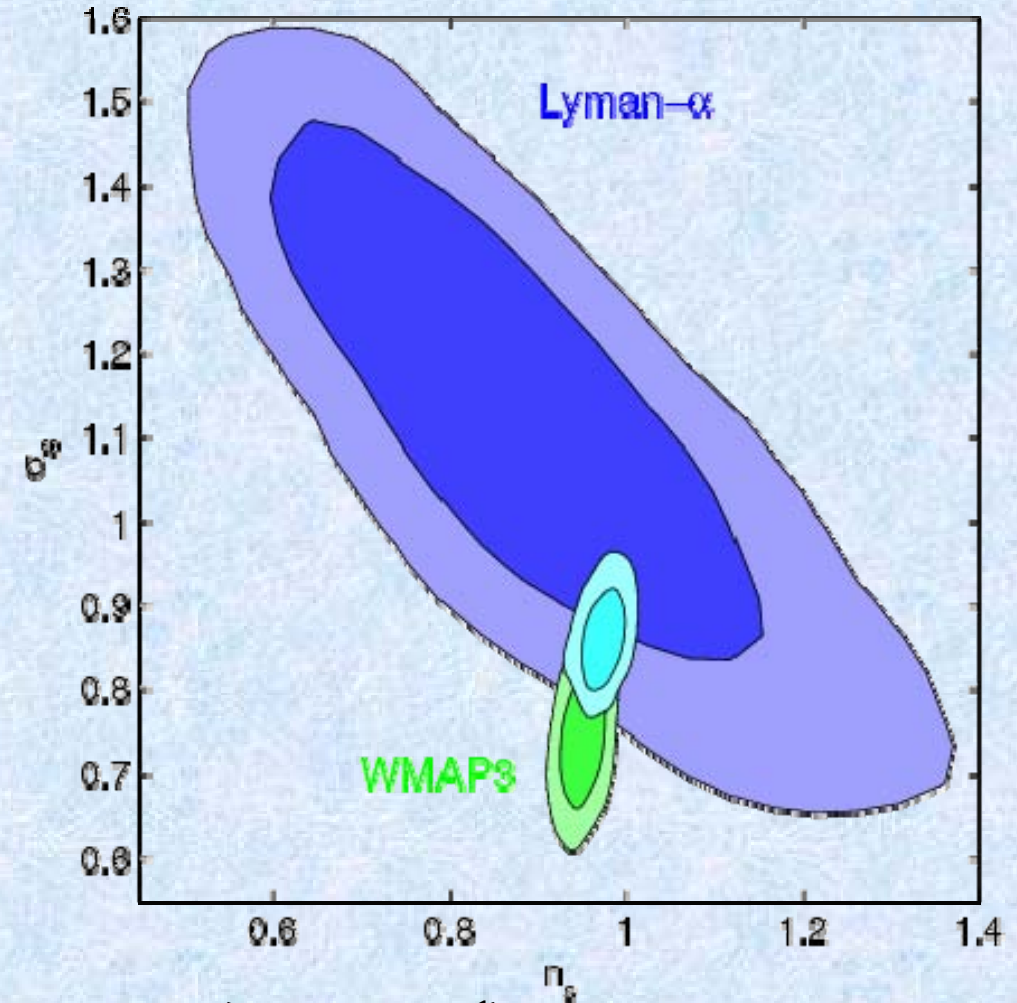

$n_{\text{run}} (0.002 \text{ Mpc}^{-1}) = 0.005 \pm 0.030$

Does not favour running: 0.005 ± 0.03

OPTICAL DEPTH

- TE-3 years contributes very little
- Alone would be an upper limit on tau
- New noise estimation is the reason
- tau from (EE-) 3yr is compatible at 2σ level with 1 yr data

(likelihood plotted keeping all other parameters fixed)

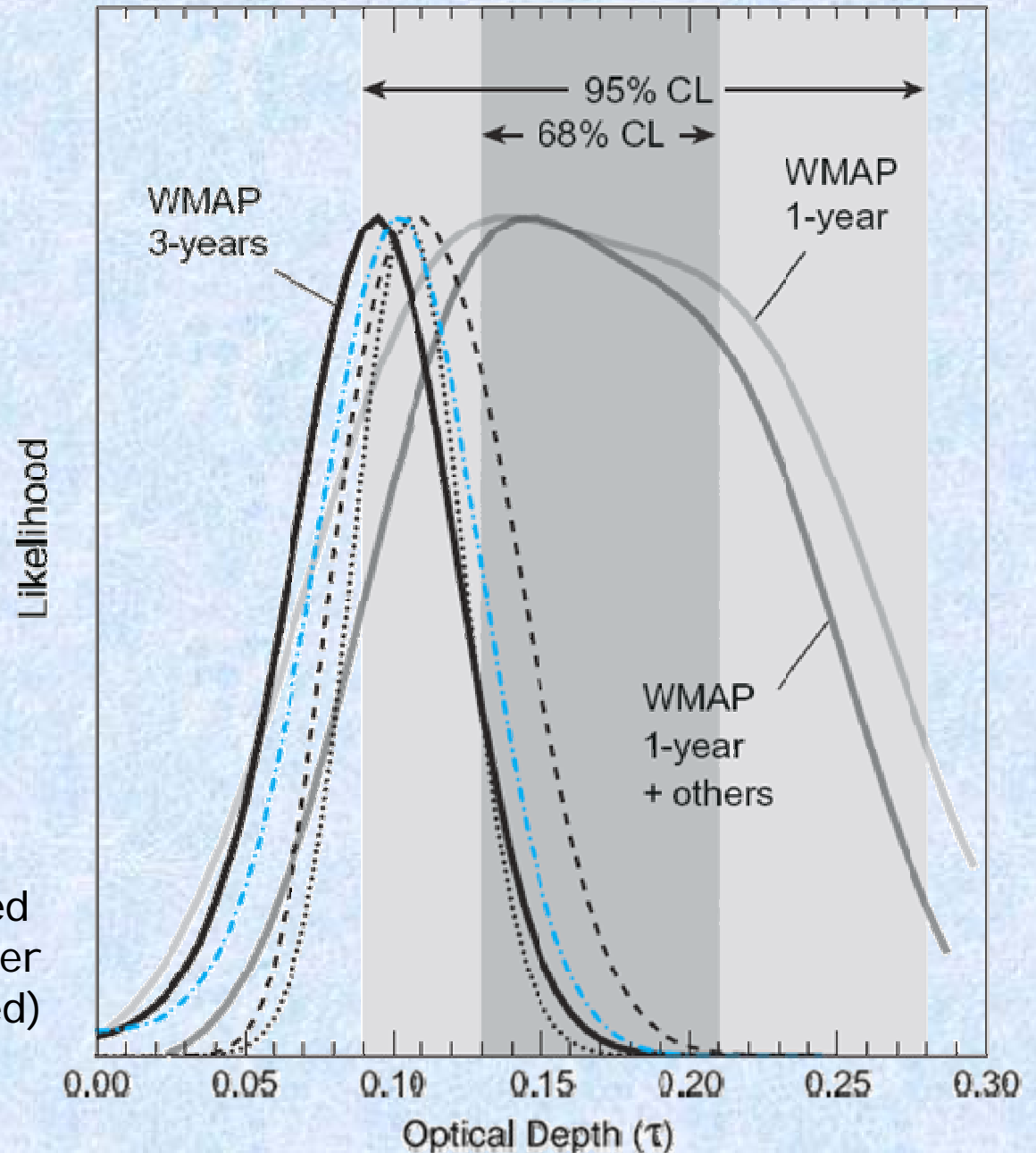

PREDICTED CL UNCERTAINTY AT LOW l

- Black = inverse Fisher Matrix
- Red = pixel-pixel noise correlations (after map-making) are ignored
- Low- l rise from $1/f$ noise (in time)
- NB: Noise negligible / signal for TT, but TE analysis **must** take the structure into account

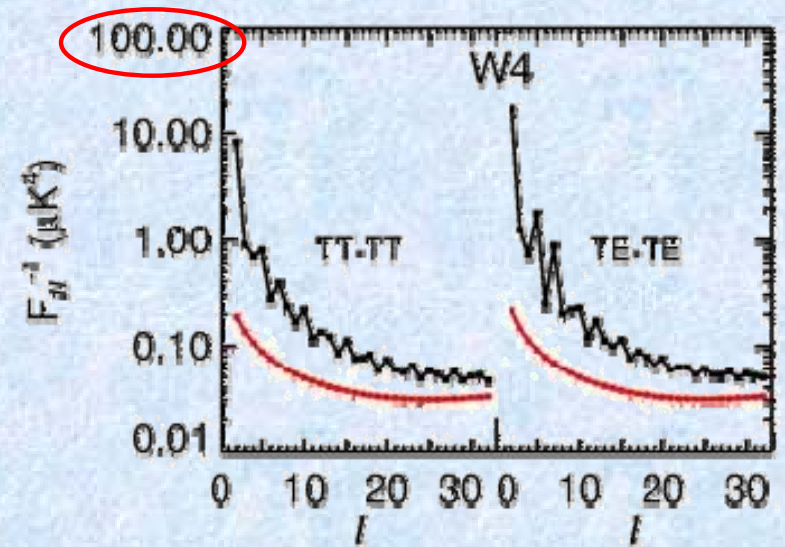
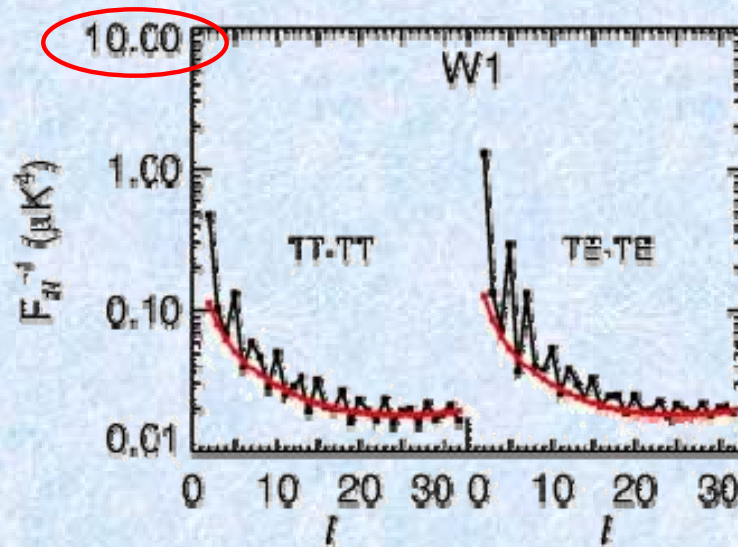
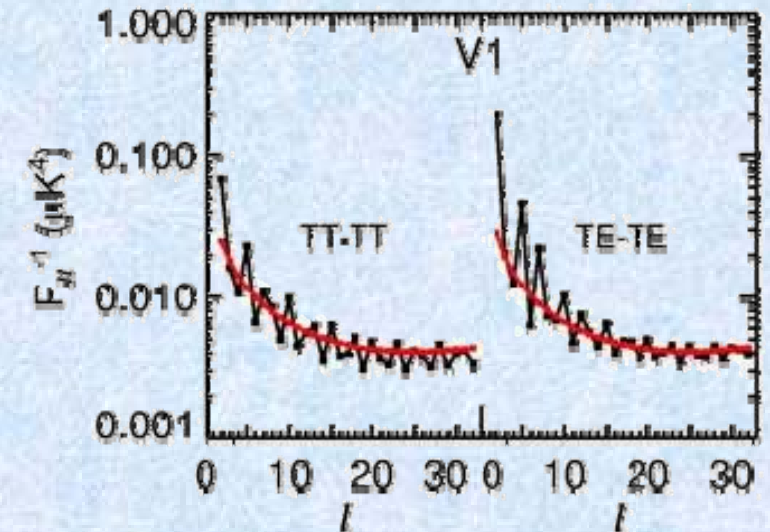
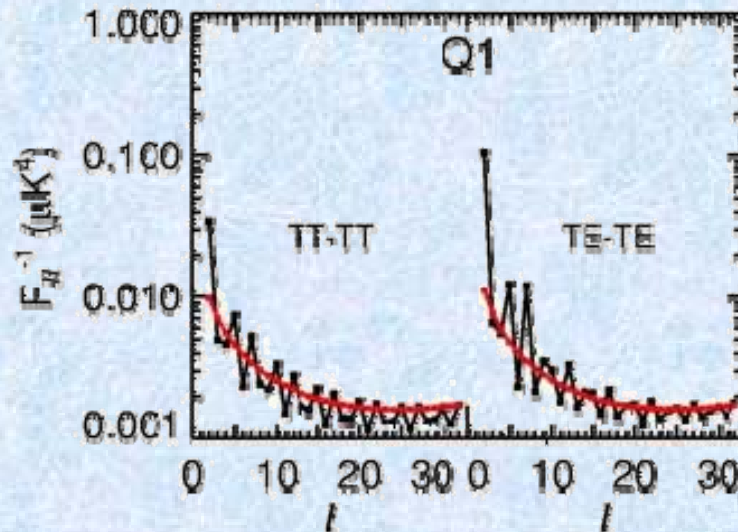

TE COMPARISON 1 VS 3 YEARS

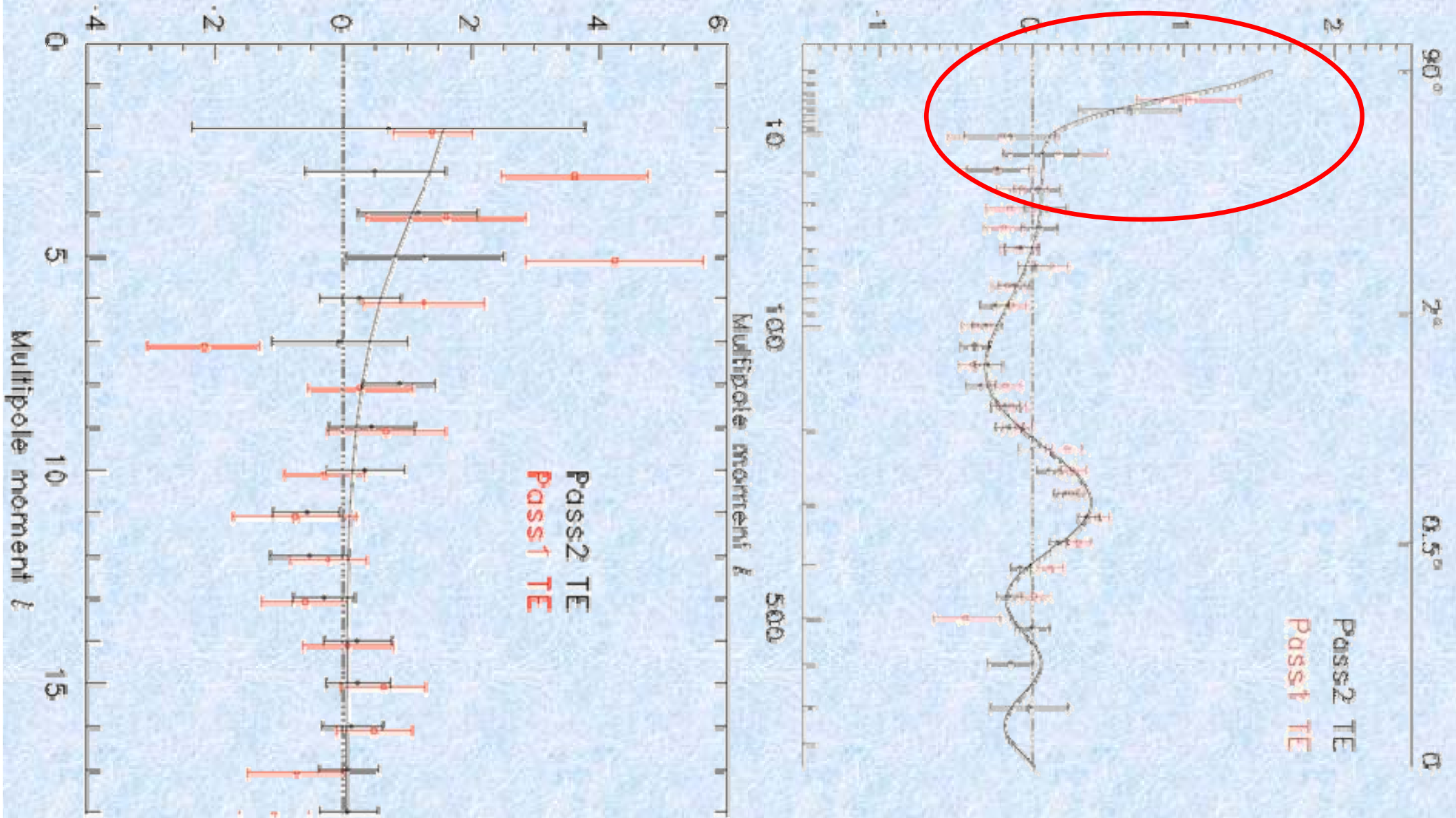

From Hinshaw @ Irvine Conference



WMAP3 CONSTRAINTS ON REIONISATION

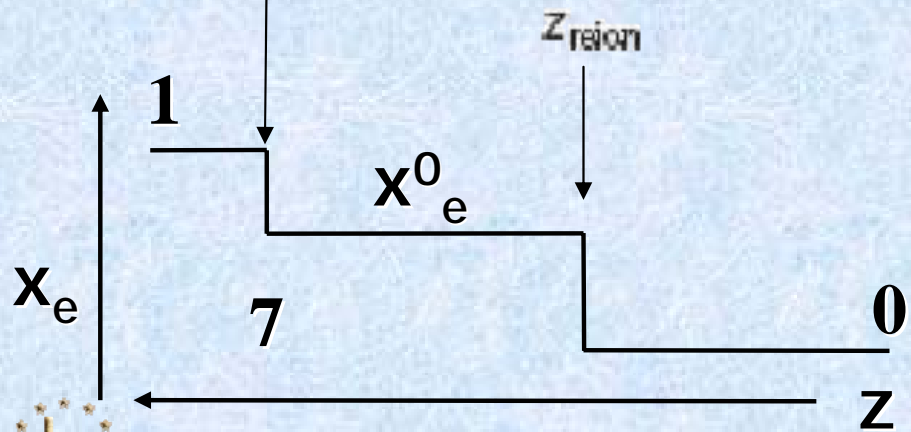
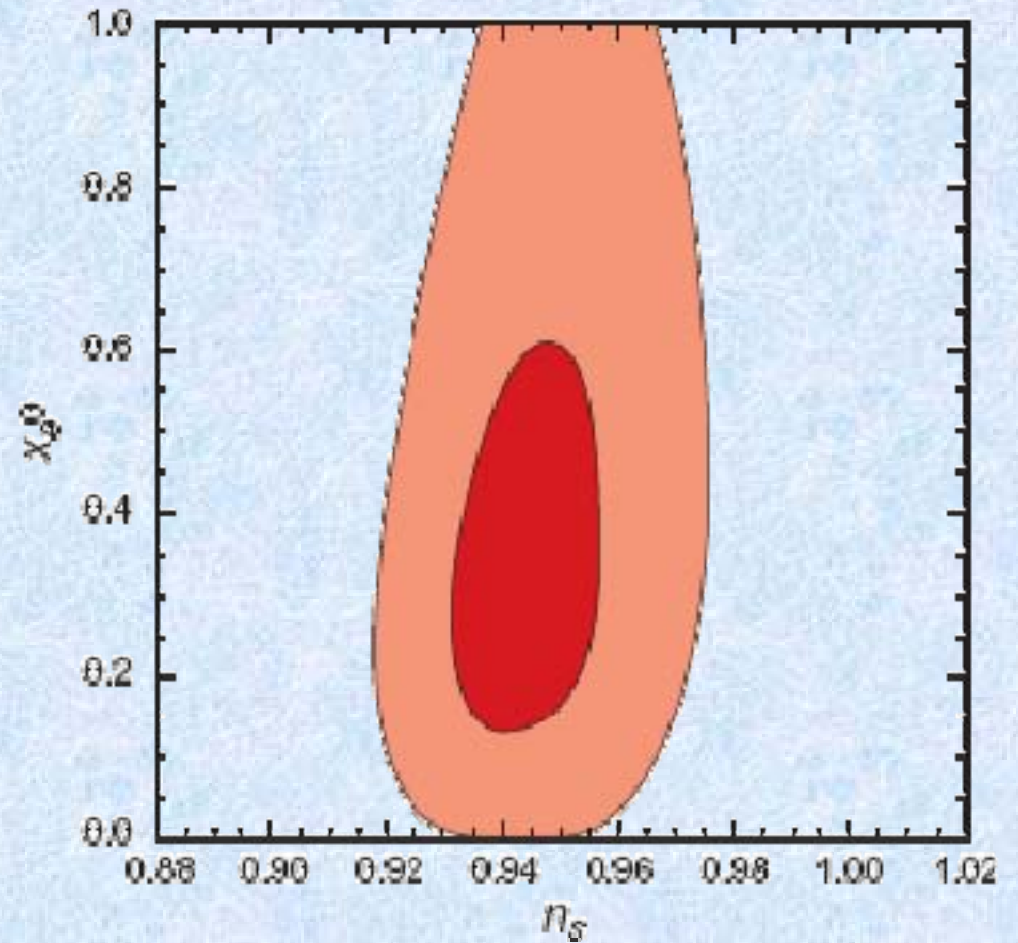
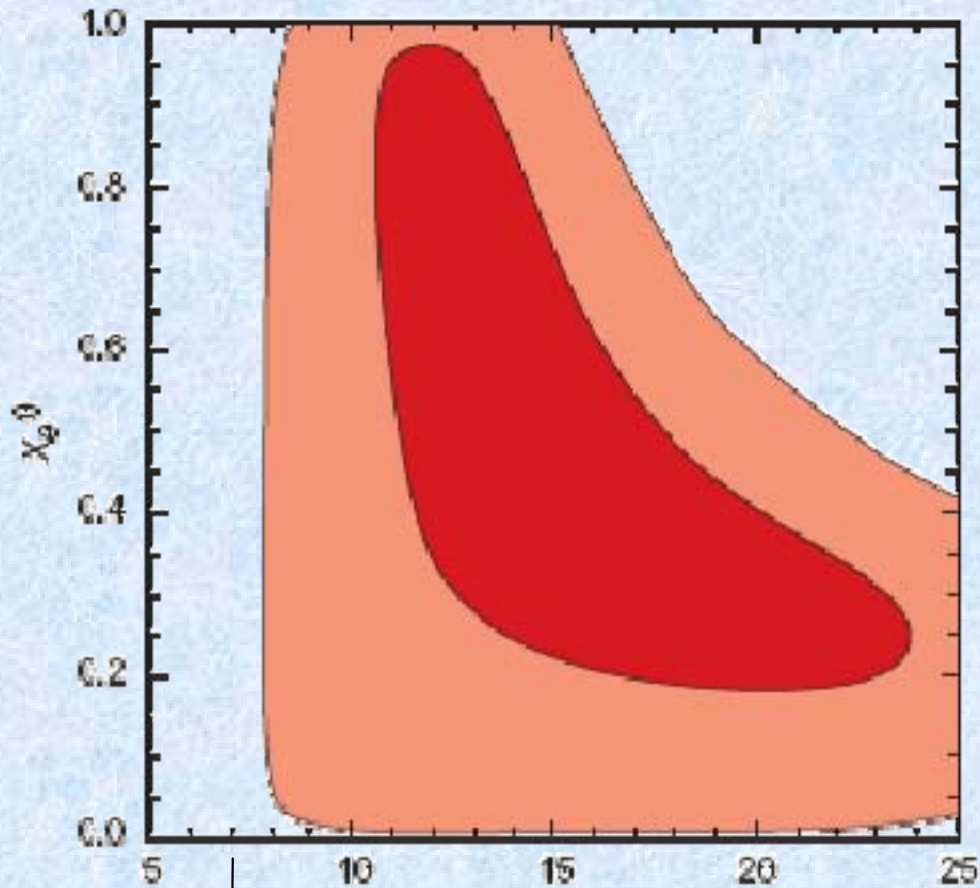

68% and 95% joint 2-d marginalized confidence level contours for $x_e^0 - z_{\text{reion}}$ for a power law LCDM

NB: If instantaneous, $z_r = 10.9^{+2.7}_{-2.3}$

WHAT'S NEEDED!



Ω/H DEGENERACY TRACK

(Setting $\Omega=1$ is not innocuous)

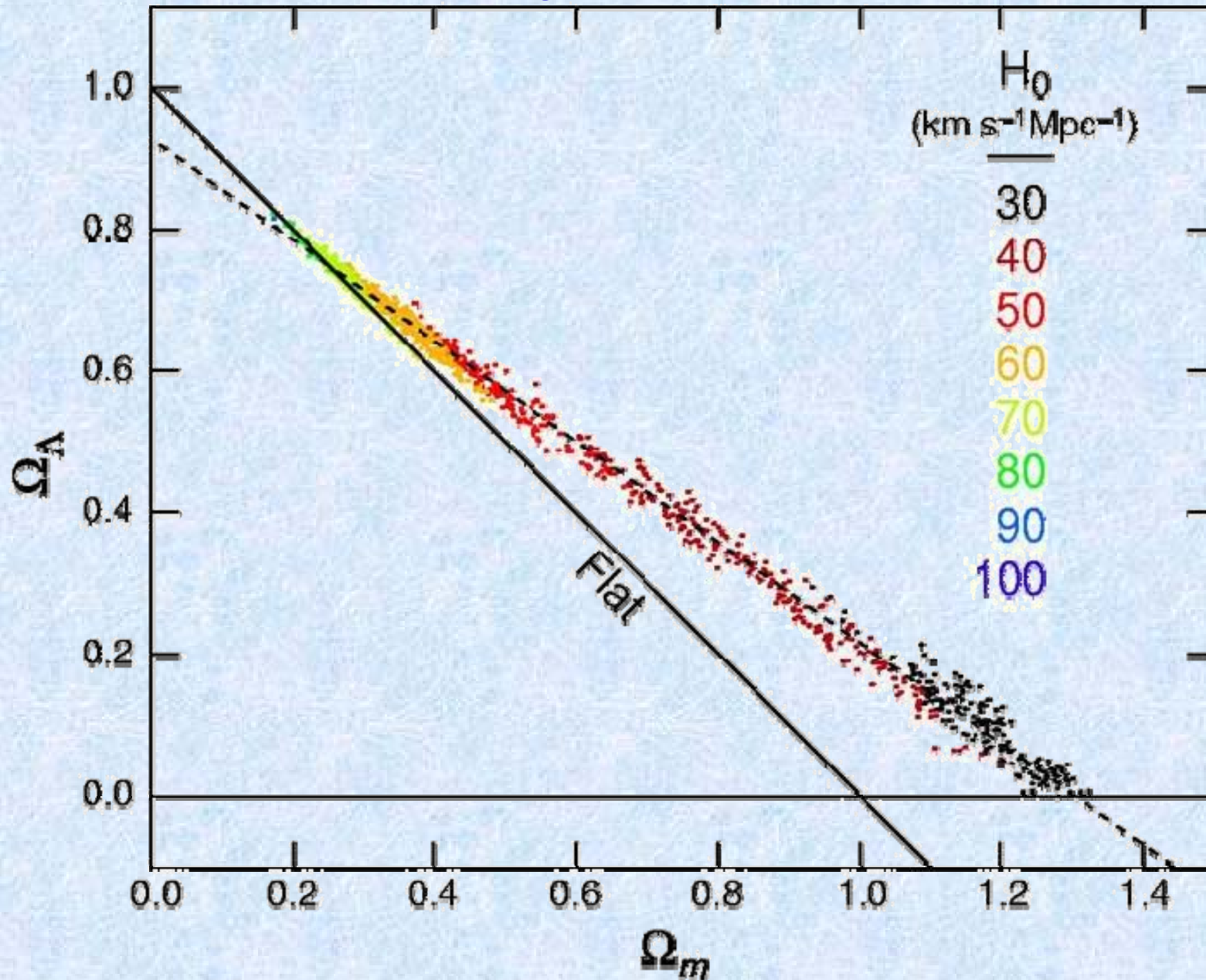

CONSTRAINING IC

Epsilon, eta et ksi correspond to successive derivatives of the inflation potential

$$\begin{cases} r = 16\varepsilon \\ n_s = 1 - 6\varepsilon + 2\eta \\ dn_s / d \ln k = -2\xi + 16\varepsilon\eta - 24\varepsilon^2 \end{cases}$$

Measurement of the amplitude of tensor modes fixes Hubble parameter H during inflation when relevant scales are leaving horizon; alternatively, fixes scalar field potential and first derivative.

e.g. Liddle & Lyth (1993), Copeland et al. (1993), Liddle (1994)

$$H \equiv \dot{a}/a \approx \frac{1}{M_{Pl}} \sqrt{\frac{V}{3}}$$
$$r = \frac{2V}{3\pi^2 M_{Pl}^4 \Delta_R^2(k_0)} = 8M_{Pl}^2 \left(\frac{V'}{V} \right)^2$$
$$V^{1/4} \leq 3.3 \times 10^{16} r^{1/4} \text{ GeV}$$

IMPLICATIONS (FOR INFLATION)

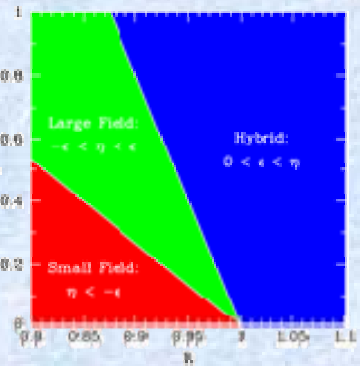
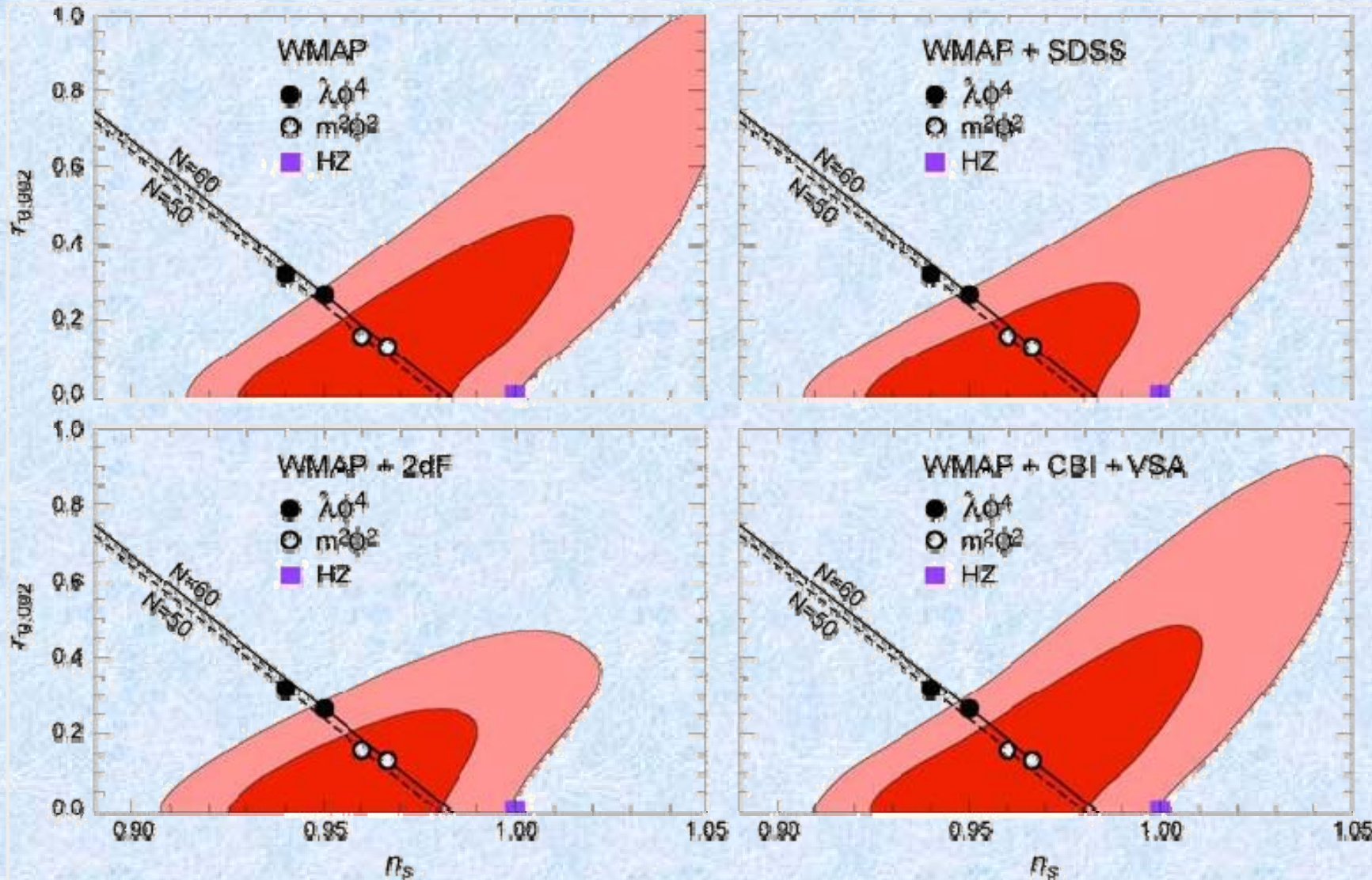

$\lambda\phi^4$ is out, but a simple $m^2\phi^2$ is still in...

NB: this is not the astroph plot

Tendencies:
 $n_s < 1$
 or τ is high
 or there are tensors
 or the model is wrong
 or we are quite unlucky...



LIMITS ON TENSOR-TO-SCALAR RATIO

Table 8: Constraints on r , Ratio of Amplitude of Tensor Fluctuations to Scalar Fluctuations (at $k = 0.002 \text{ Mpc}^{-1}$)

Data Set	r (no running)	r (with running)
WMAP	0.55 (95% CL)	1.5 (95% CL)
WMAP+BOOM+ACBAR	0.63 (95% CL)	1.4 (95% CL)
WMAP+CBI+VSA	0.55 (95% CL)	1.1 (95% CL)
WMAP+2df	0.30 (95% CL)	1.0 (95% CL)
WMAP+SDSS	0.28 (95% CL)	0.67 (95% CL)

$$r < 0.55 @ 95\% \text{ CL} \Rightarrow \Omega_{\text{GW}} h^2 < 1. \cdot 10^{-12} (@95\% \text{ CL})$$

The Inflationary Zoo

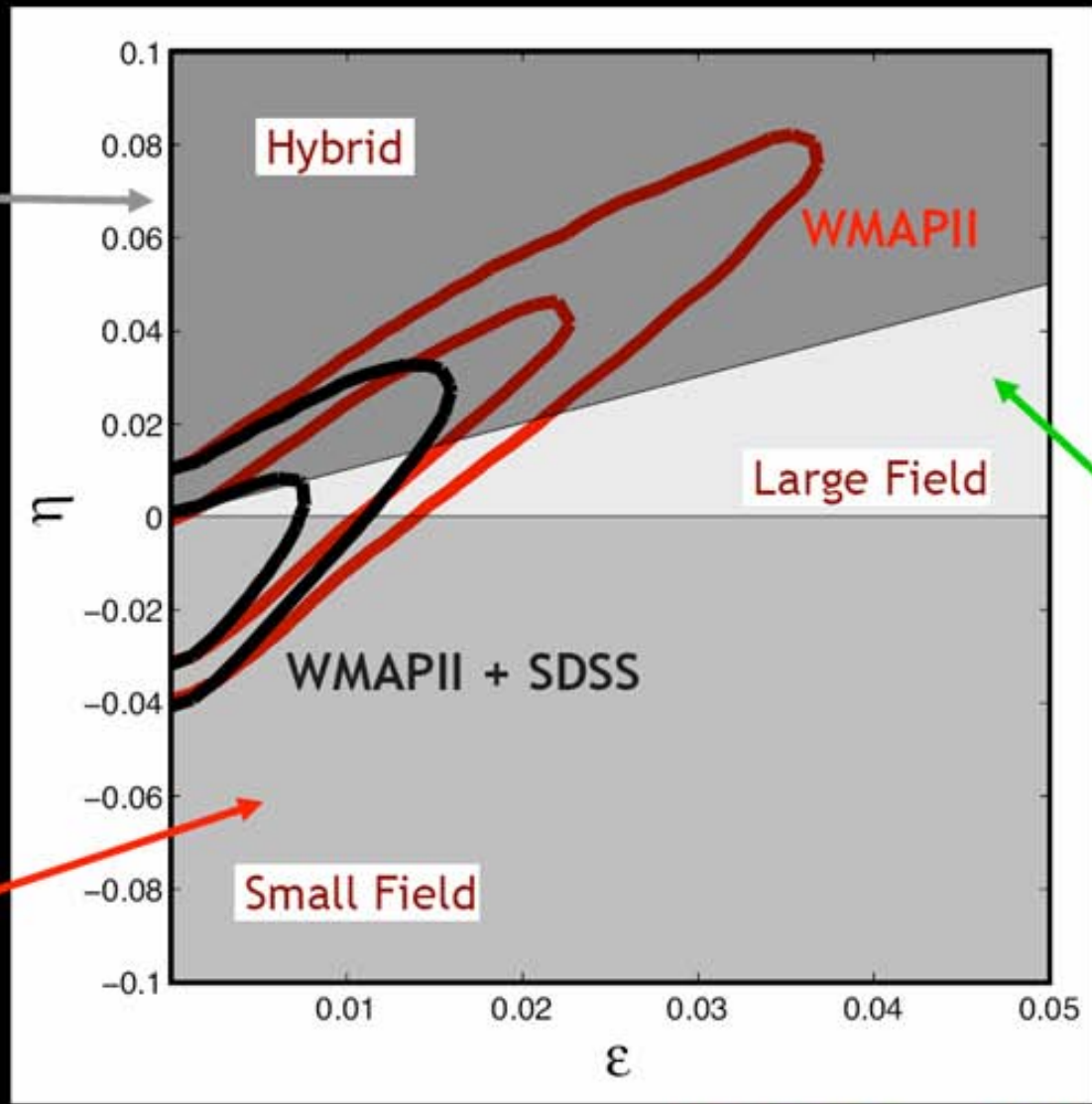
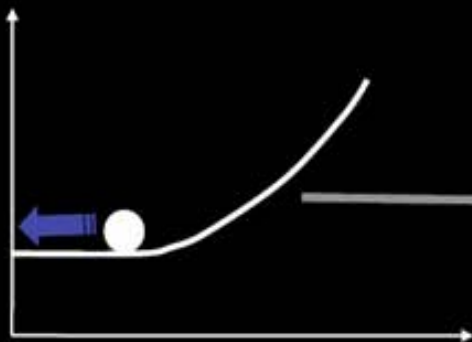

$$\begin{cases} r = 16\epsilon \\ n_s = 1 - 6\epsilon + 2\eta \\ dn_s / d \ln k = -2\xi + 16\epsilon\eta - 24\epsilon^2 \end{cases}$$

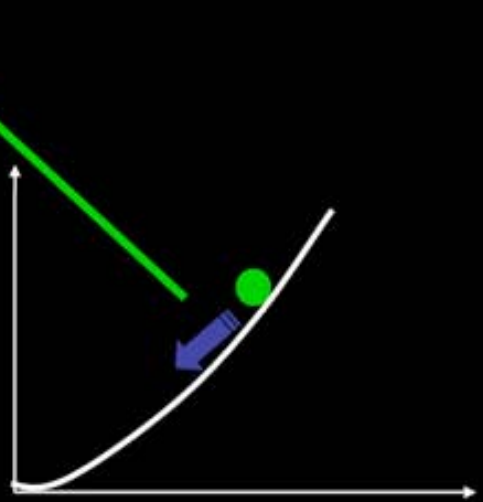
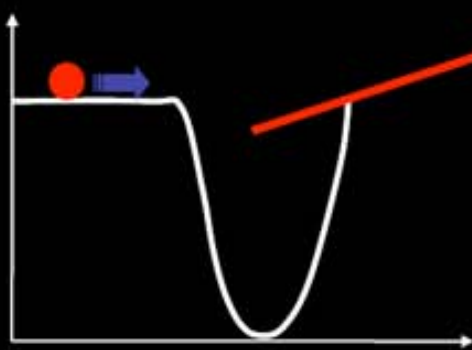

Peiris & Easter (2006)

Constraints on first two HSR parameters at $k=0.002 \text{ Mpc}^{-1}$

CONSTRAINTS ON LARGE-FIELD MODELS

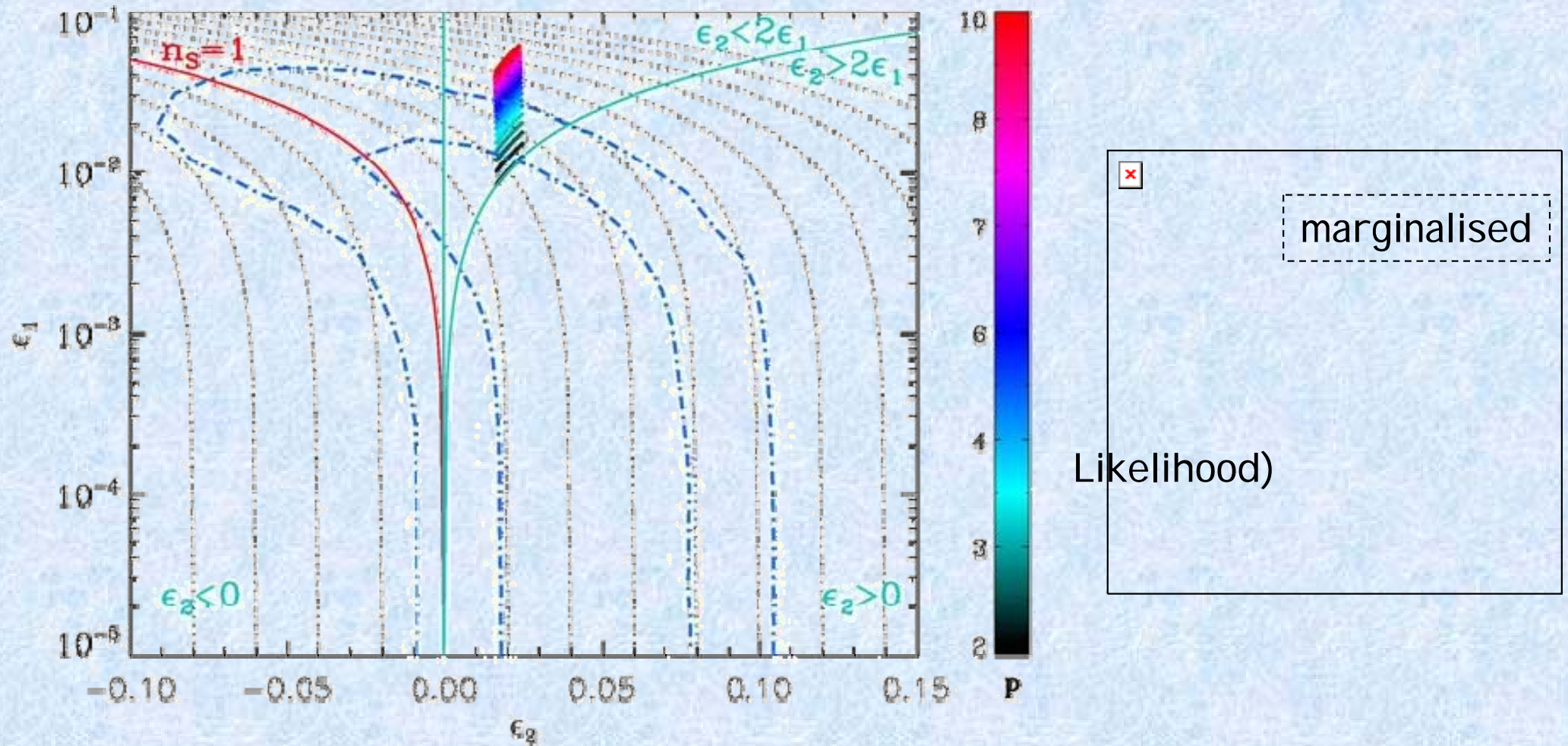

- ⊕ Models $V \propto \Phi^p$
- ⊕ Dotted = constant spectral index lines
- ⊕ $p > 4$ are in trouble (one start constraining the potential shape)

A SIGN OF TRANS-PLANCKIAN PHYSICS?

- ✚ Probleme theorique trans-Planckien
J. Martin and R. Brandenberger,
PRD 63 123501, 2001 (hep-
h/0005209)
- ✚ WMAP et les oscillations :
 - J. Martin & C. Ringeval, PRD 69
064406, 2004 (astro-ph/
0310382);
 - J. Martin & C. Ringeval, PRD 69
127303, 2004 (astro-ph/
0402609);
 - J. Martin & C. Ringeval, JCAP 0501
007, 2004 (astro-ph/0405249)
- ✚ Ongoing discussions with WMAP
team, stay tuned...

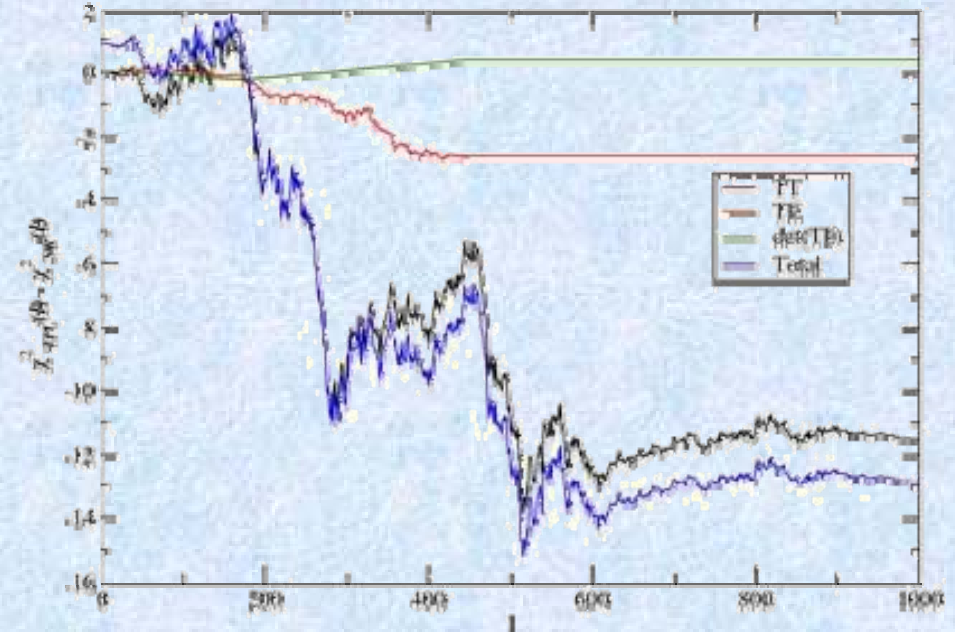
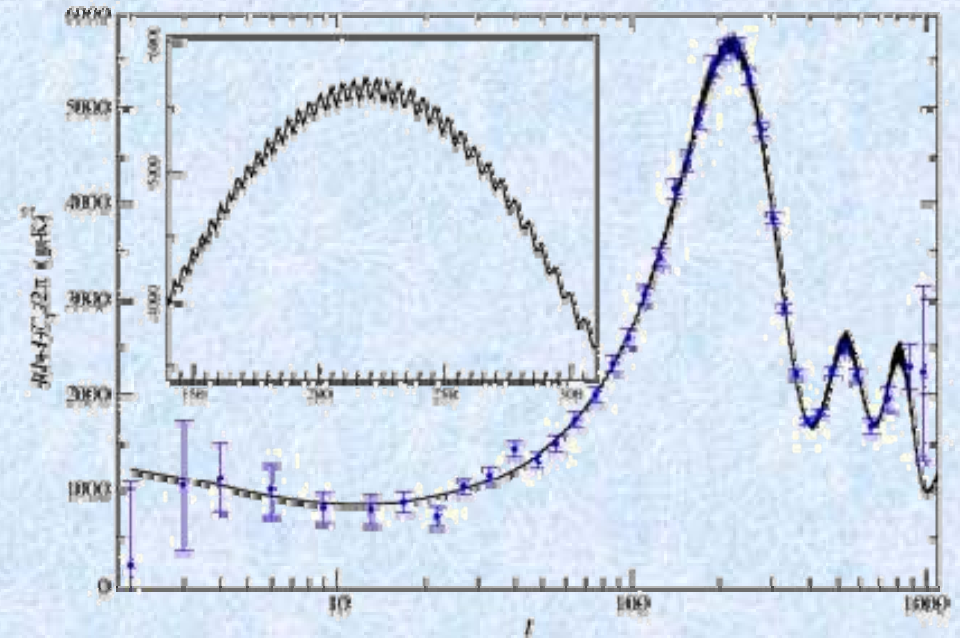

INVESTIGATING DARK ENERGY

✚ The equation of state parameter $w(z) = p/\rho$

■ $w = -1$

■ $w = \text{const} \neq -1$

■ $w(z)$

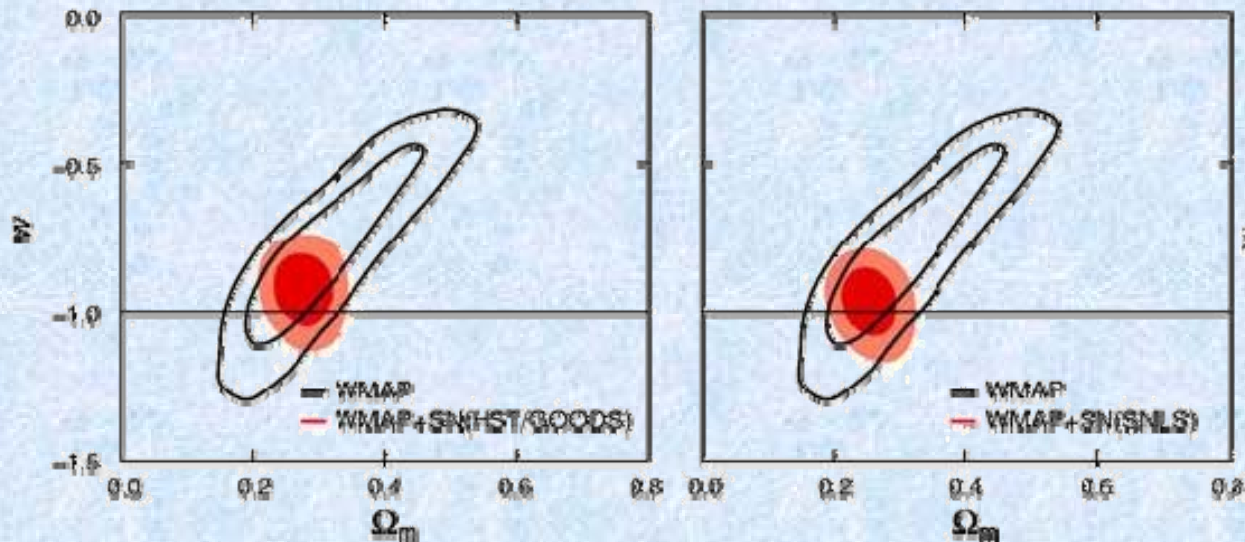

Spergel et al 2006

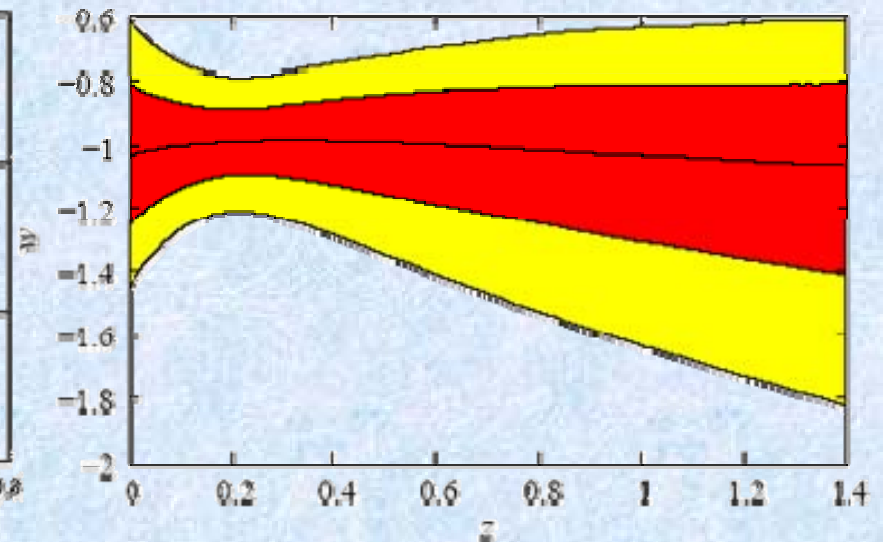

Seljak et al 2005

DARK ENERGY

Clustering dark energy $c_s^2=1$ $w \neq -1$

Ignoring fluctuations in DE

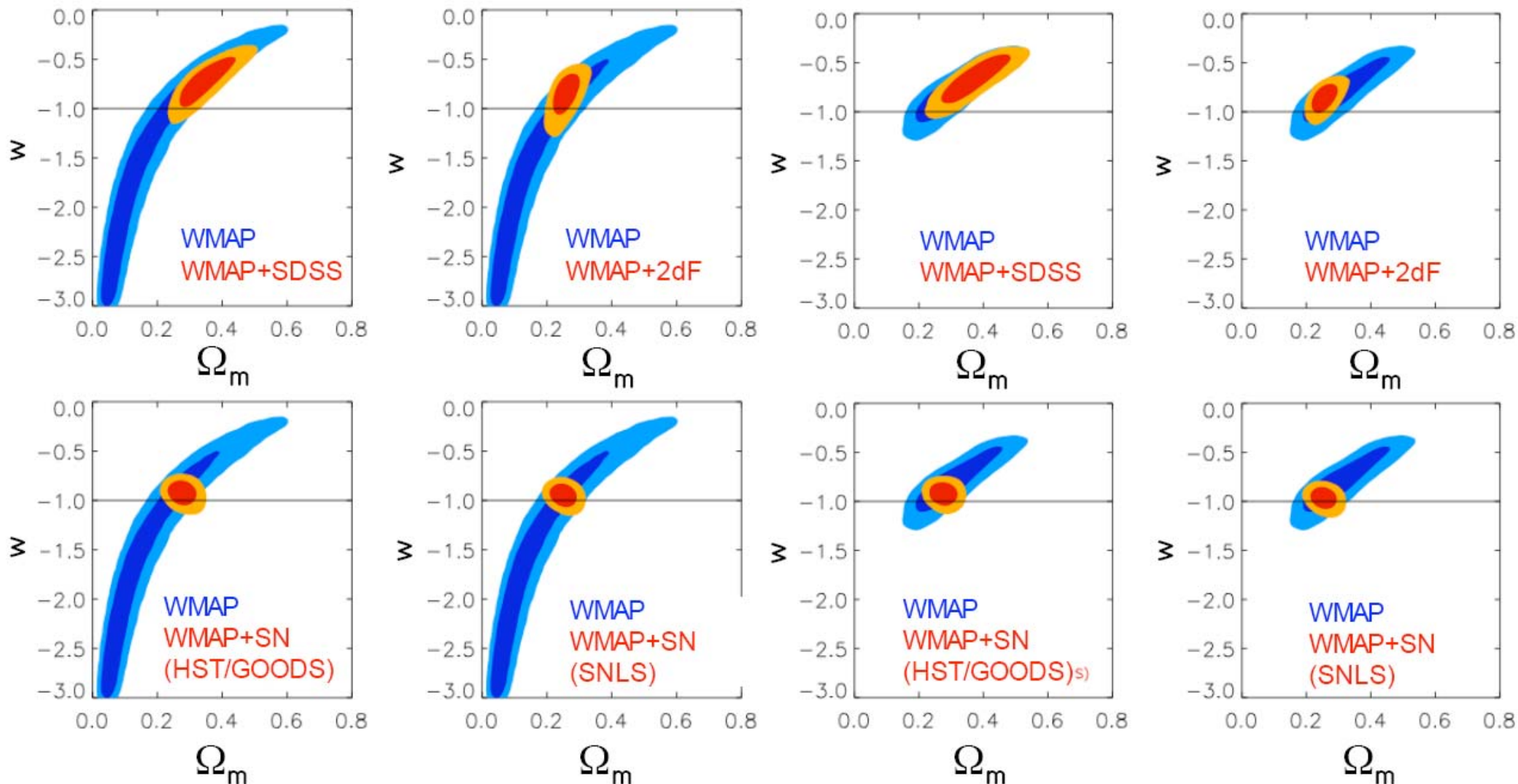

MATTER ISOCURVATURE MODES

- ✚ Possible in two-field inflation models, e.g. 'curvaton' scenario
- ✚ Curvaton model gives adiabatic + correlated CDM or baryon isocurvature, no tensors
- ✚ CDM, baryon isocurvature indistinguishable – differ only by cancelling matter mode

Constrain B = ratio of matter isocurvature to adiabatic

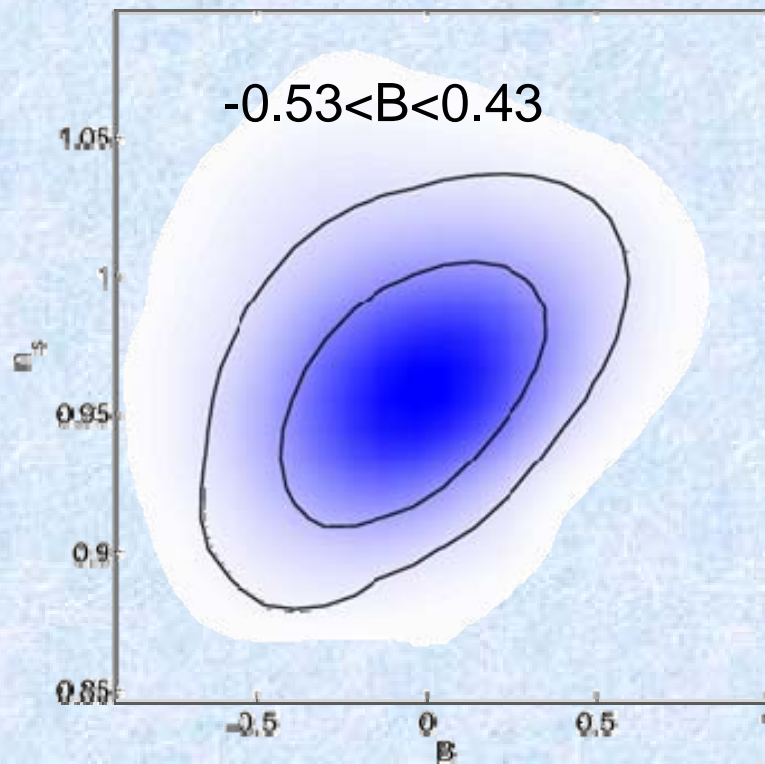

WMAP1+2df+CMB+BBN+HST

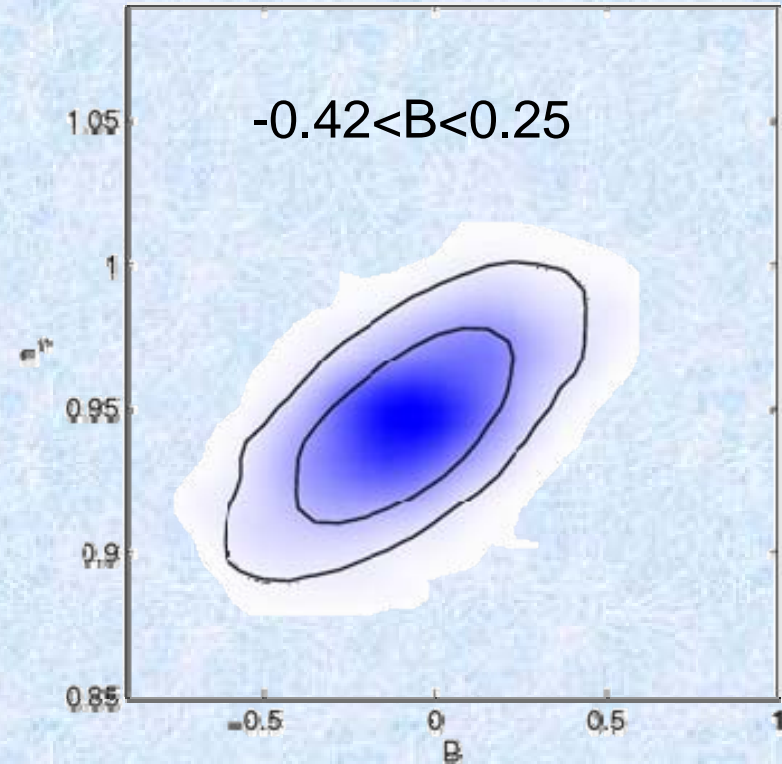

WMAP3+2df+CMB

Gordon, Lewis: astro-ph/0212248

Lewis @ Moriond-march06

WHAT WE NOW KNOW

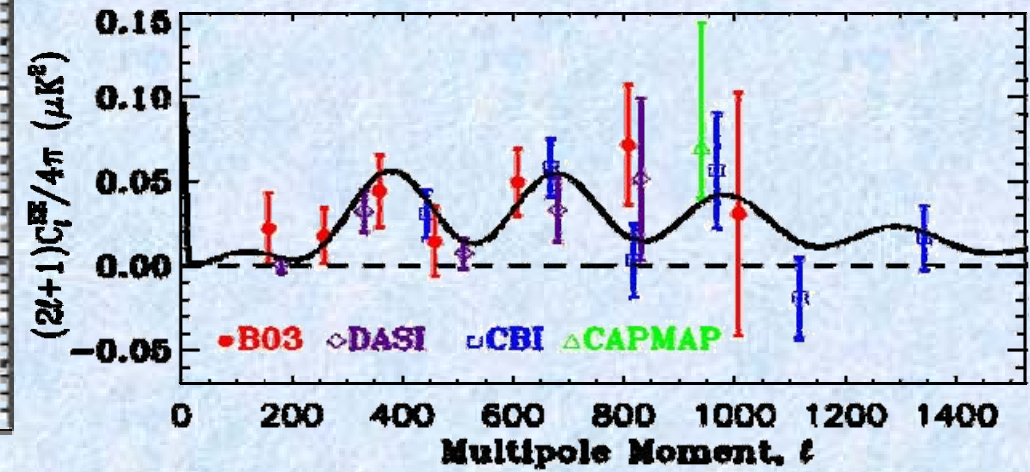
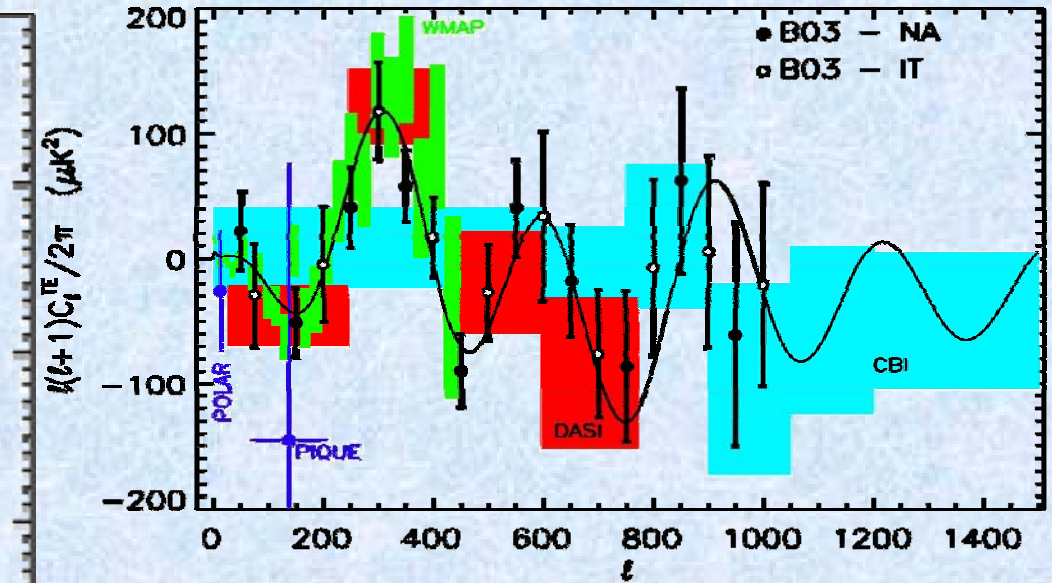
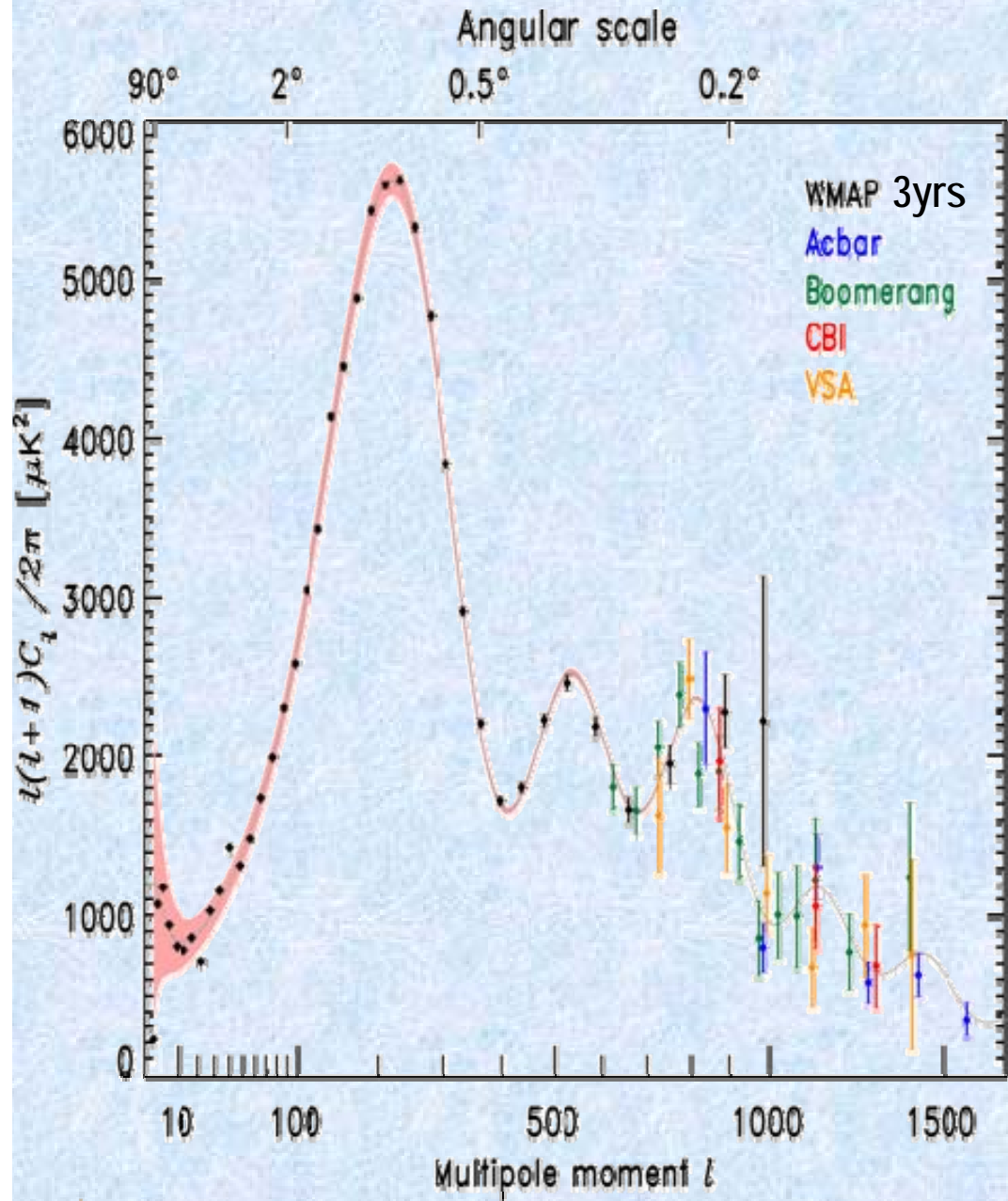
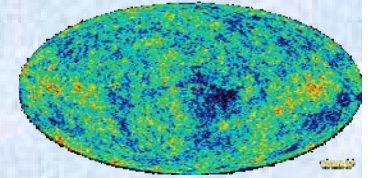

WITH SOME INTERESTING TENSIONS...

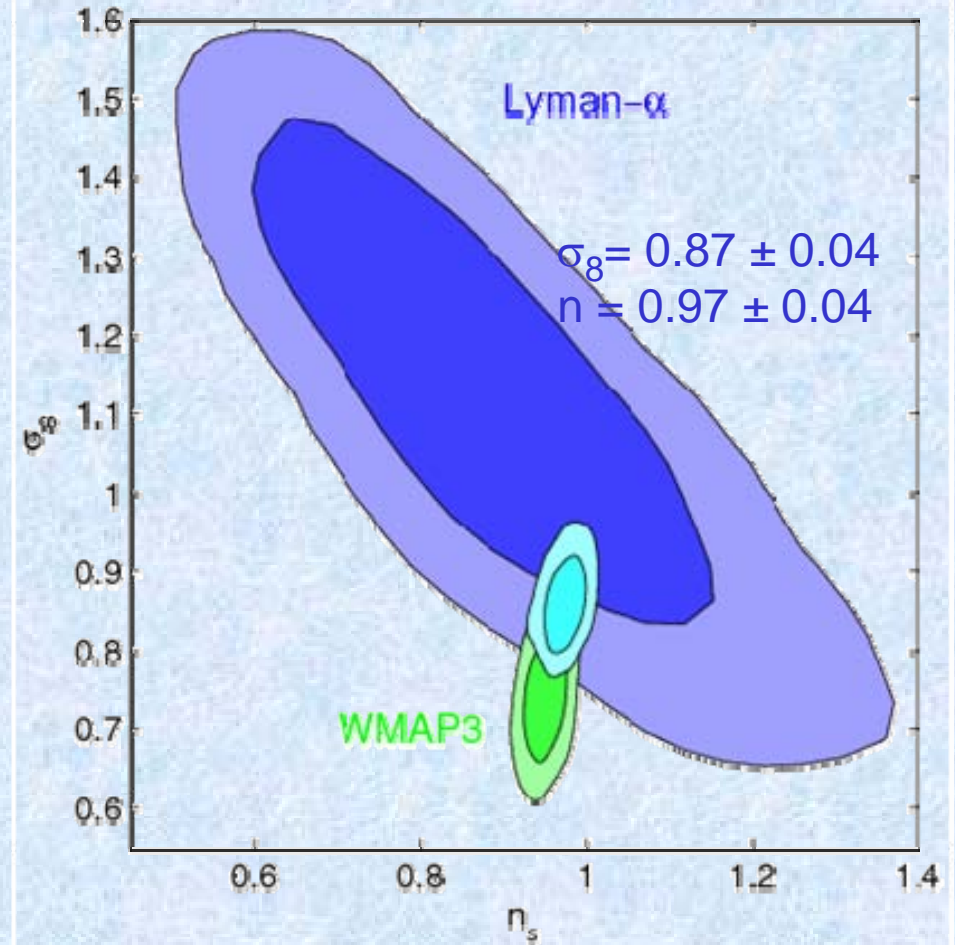
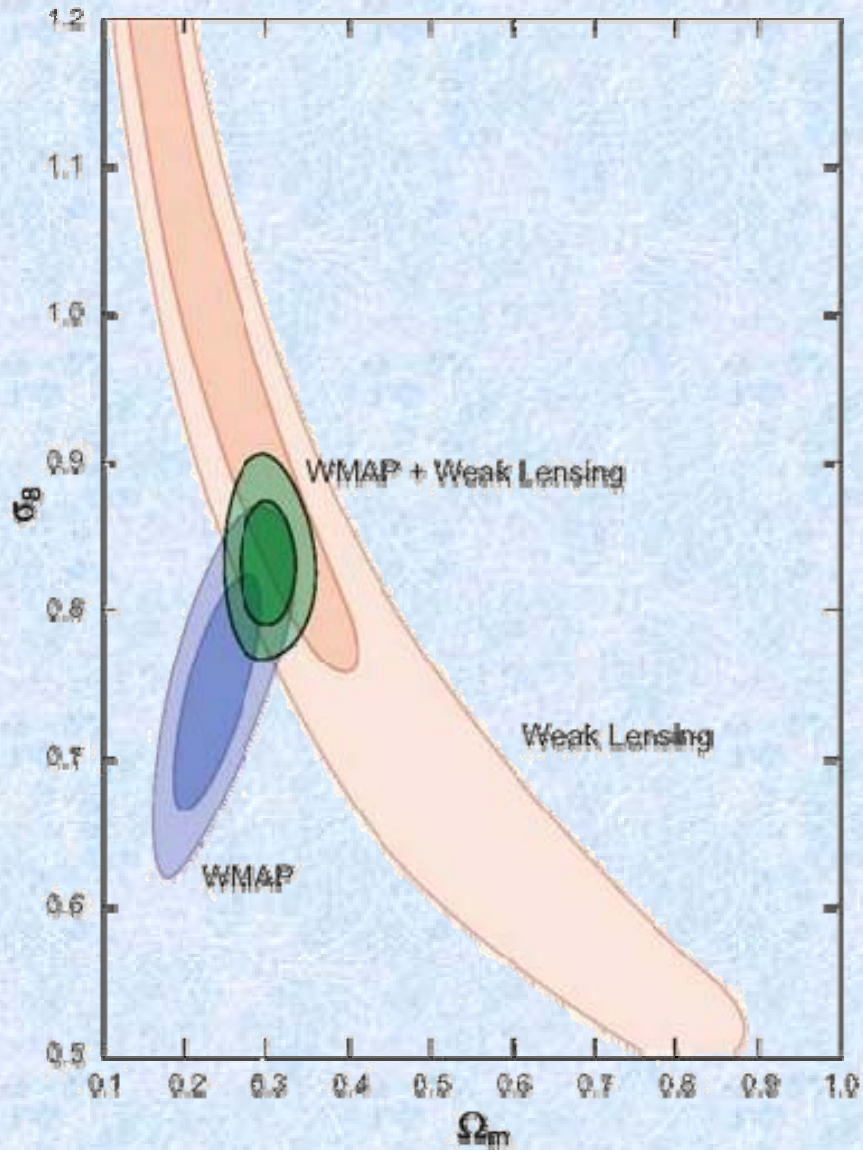

+ Li7...

THE FUTURE



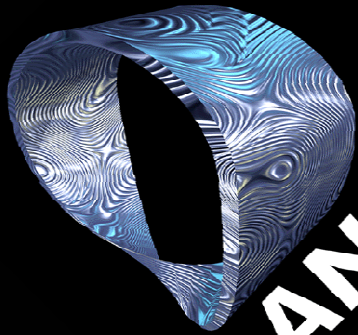

PLANCK



Launch
in 2008



THE PLANCK CONCEPT



- + An Instrument able to perform the “ultimate” measurement of the CMB temperature anisotropies:
 - full sky coverage and angular resolution covering all scales at which the CMB primary anisotropies contain information ($\sim 5'$)
 - sensitivity essentially limited by ability to remove the astrophysical foregrounds, implying enough sensitivity combined with a large frequency coverage from 30 GHz to 1 THz (provided by the two instruments: HFI + LFI)
 - + get the best performances possible on the polarization of the CMB with the technology available
- ⇒ can be achieved with a small number of detectors in each frequency band, limited by the photon noise of the background (for the CMB ones)

PLANCK VS WMAP: 1 YEAR SENSITIVITY GOALS



Center Freq. (GHz)	30	44	70	100	143	217	353	545	857
Angular Resolution (FWHM, arcmin)	33	24	14	9.5	7.1	5	5	5	5
Average $\Delta T/T_I$ per pixel[#]	2.0	2.7	4.7	2.5	2.2	4.8	14.7	147	6700
Average $\Delta T/T_{U,Q}$ per pixel[#]	2.8	3.9	6.7	4.0	4.2	9.8	29.8		
Sensibilité in I [μK] per pixel (FWHM)	5.5	7.4	12.8	6.8	6.0	13,1	40,14		
Sensibilité in I [μK.deg] [$\sigma_{\text{pix}} \Omega_{\text{pix}}^{1/2}$]	2.7	2.6	2.6	0,96	0,63	0,97	2,9		
Sensibilité in Q or U [μK.deg] [$\sigma_{\text{pix}} \Omega_{\text{pix}}^{1/2}$]	4.5	4.6	4.6	1.85	1.45	2.39	7.26		

WMAP Center Freq.	23	33	41	61	94
Angular resolution (FWFM arcmin)	49	37	29	20	12,6
μK per $3,2 \cdot 10^{-5}$ sr pixel (22'x 22')	38.9	39,9	41	48	46
Sensibilité en I [μK.deg], 1 yr (8 yr)	12.6 (4.5)	12.9 (4.6)	13.3 (4.7)	15.6 (5.5)	15.0 (5.3)

The aggregated sensitivity of the 3 core CMB channels of Planck, @ 100, 143, 217GHz (~0.5 μ K.deg in T, 1 μ K.deg QU) will be unprecedented and quite challenging in terms of control of systematics

PLANCK NEEDED BREAKTHROUGHS



- ✚ The sensitivity goals of Planck **requires 5 technological performance** never achieved in space before
 - Sensitive & fast bolometers with
 - $NEP < 2 \cdot 10^{-17} \text{ W/Hz}^{1/2}$ & time constants typically $< 5 \text{ msec}$
(thus cooling them to 100 mK, very low heat capacity and charged particles sensitivity)
 - total power read out electronics with very low noise
 - $< 6 \text{ nV/Hz}^{1/2}$ from 10 mHz to 100 Hz
 - temperature stability for detector plate
 - $< 40 \text{ nK}$ $10 \text{ nV/Hz}^{1/2}$ from 10 mHz to 100 Hz
 - temperature stability for 4K box
 - $< 10 \text{ } \mu\text{K/Hz}^{1/2}$ from 10 mHz to 100 Hz
 - 100 GHz low noise HEMT amplifiers (\Rightarrow cooled to 20K) & very stable cold reference loads (4K)

- ✚ Additionally:
 - low emissivity very low side lobes telescope (strongly under-illuminated)
 - no windows, minimum warm surfaces between detectors and telescope
 - active cooling
 - 4K, 1.6K and 100mK for HFI
 - 20K for LFI with large cooling power K (0.7W)
 - NB: 100mK cooling by dilution cooler **does not tolerate** micro-vibrations at sub-mg level or $7 \cdot 10^{10}$ He atoms accumulated on dilution heat exchanger (typically He pressure $1 \cdot 10^{-10}$ mb)

PLANCK-HFI PERFORMANCE



Tested flight bolometers

		100	143	217	353
beam size	arcmin	9,5	7,1	5	5
n pixels		1,65E+06	2,95E+06	5,94E+06	5,94E+06
system sensitivity to T	$\mu\text{K rt s}$	28,8	16,4	26,1	93,9
system sensitivity to Q,U	$\mu\text{K rt s}$	43,8	38,1	58,9	262
avg time/pixel	s	19,2	10,7	5,3	5,3
$\Delta T/\text{pixel}$	μK	6,587279	5,021682	11,32264	40,76182
$\Delta T/T/\text{pixel}$	10^{-6}	2,4	1,9	4,2	15,0
$\Delta T/T/\text{pixel bluebook}$	10^{-6}	2,5	2,2	4,8	14,7
$\Delta(Q,U)/\text{pixel}$	μK	10,0	11,6	25,6	114
$\Delta(Q,U)/T/\text{pixel}$	10^{-6}	3,7	4,3	9,4	41,9
$\Delta(Q,U)/T/\text{pixel bluebook}$	10^{-6}	4	4,2	9,8	29,8

Survey Time years 1

T Sens ($\mu\text{K} \cdot \text{arcmin}$)		63	36	57	204
T Goals Blue Book		65	42	65	200
Q, U Sens ($\mu\text{K} \cdot \text{arcmin}$)		95	83	128	568
Q, U Goals Blue Book		104	81	134	406

As of 17 February 2006



BO3 DEEP SURVEY

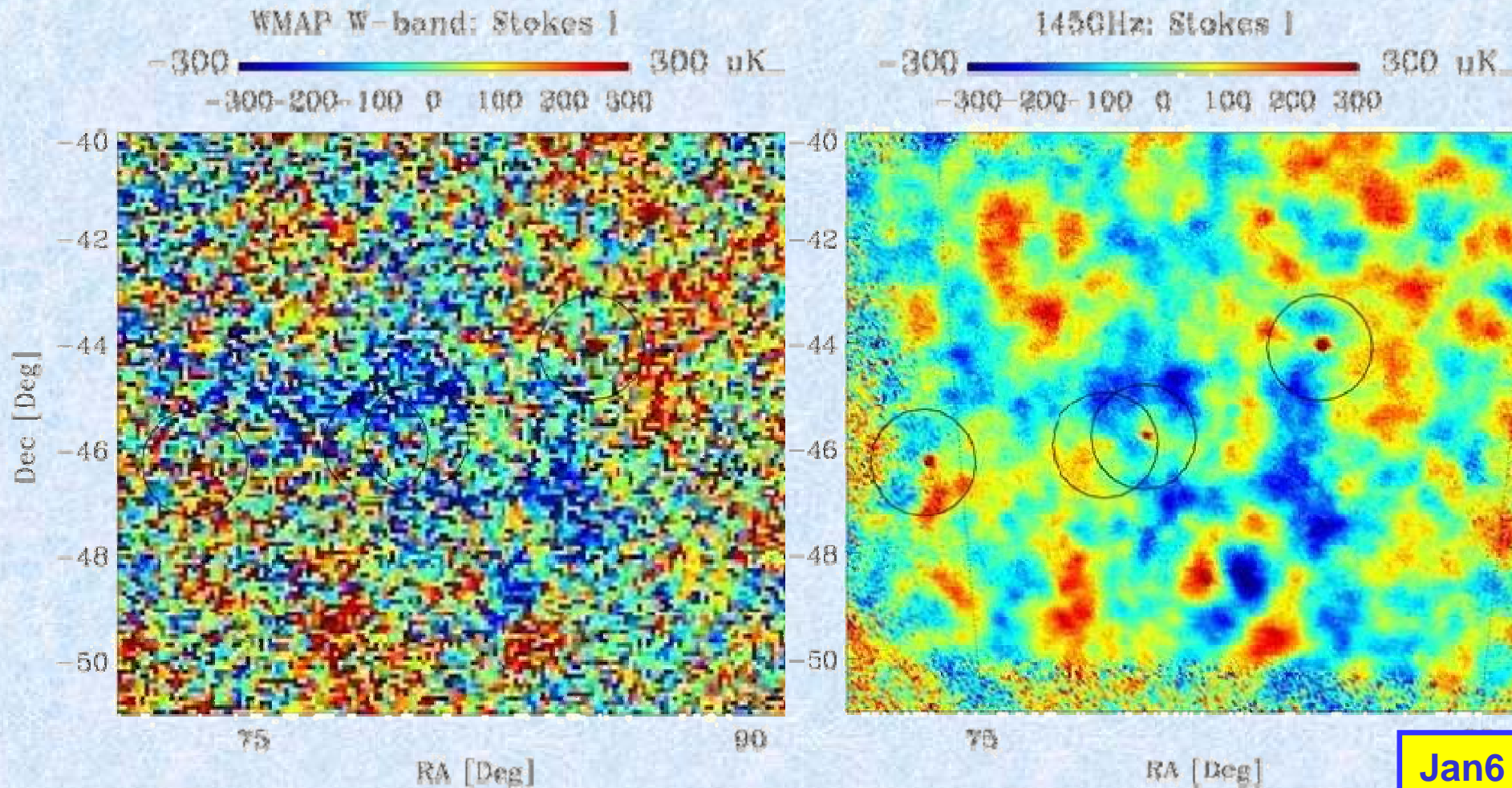

Masi et al. astro-ph/0507509

**Jan 6 2003
+ 10 days**

A foretaste of Planck-HFI @ 145 GHz but:

- + $w_1 = 82 \mu\text{K} \cdot \text{arcmin}$, while HFI goal is $w_1 = 42 \mu\text{K} \cdot \text{arcmin}$ @ 143GHz (OK FM bolos delivered ~36)
- + Planck has matching sensitivities in 9 frequency bands, e.g. $\sim 60 \mu\text{K} \cdot \text{arcmin}$ @ 100 & 217 GHz
- + 90 deg^2 , i.e. 0.2% of the sky covered, instead of 100% (and deep surveys in Planck too)



TE & EE FORECASTS

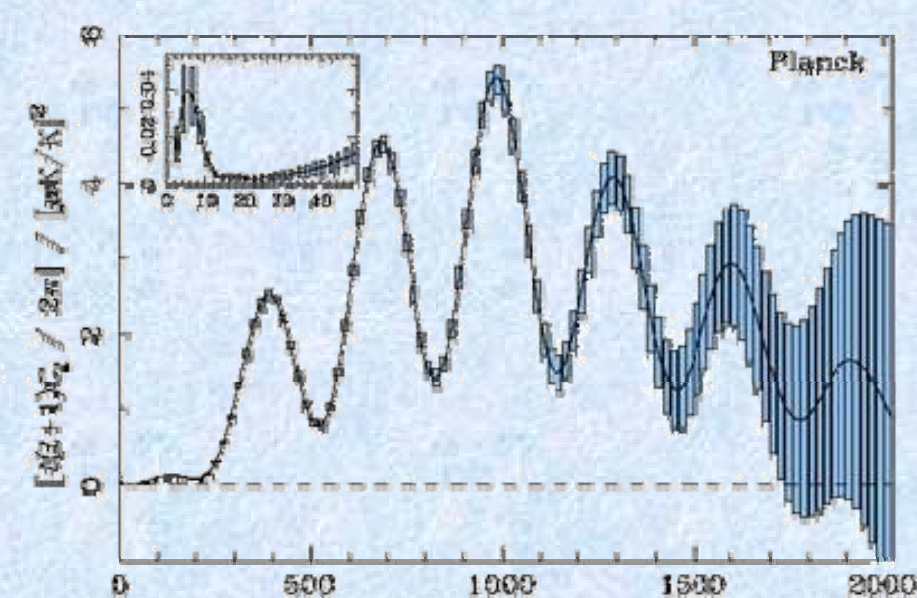
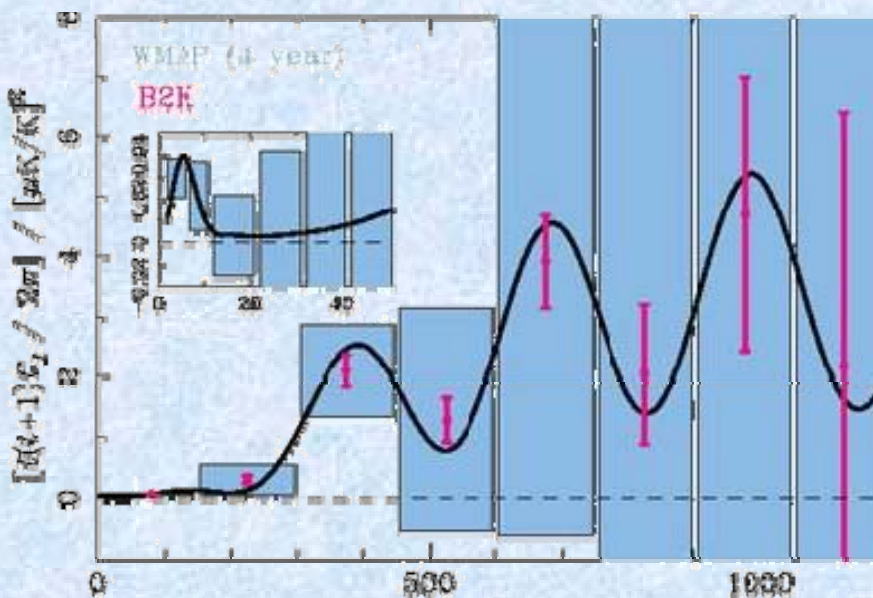
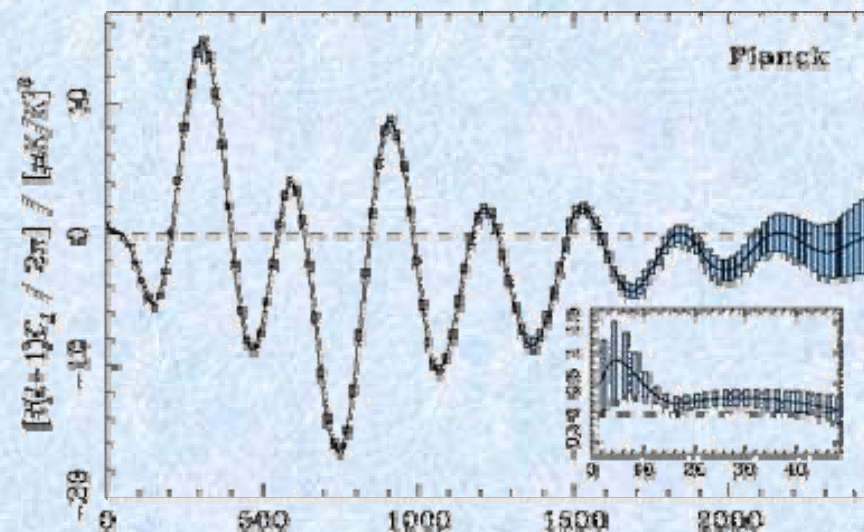
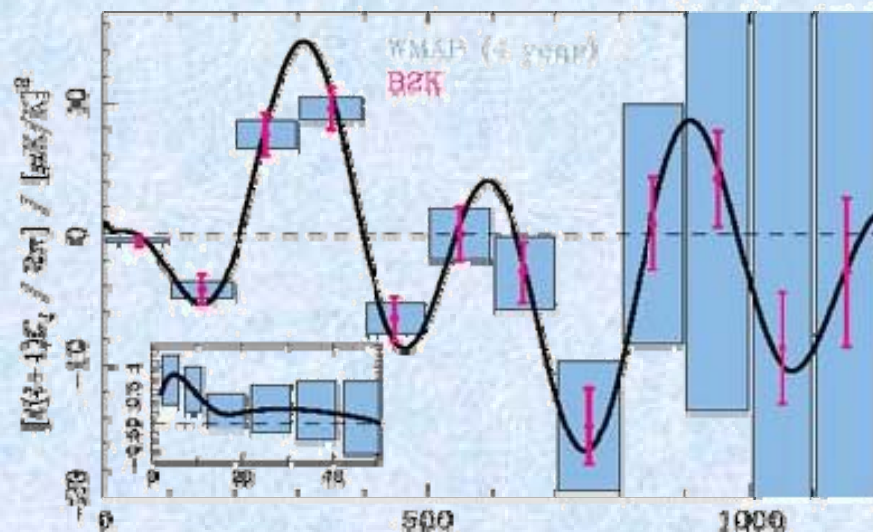

ACCURACY FORECAST

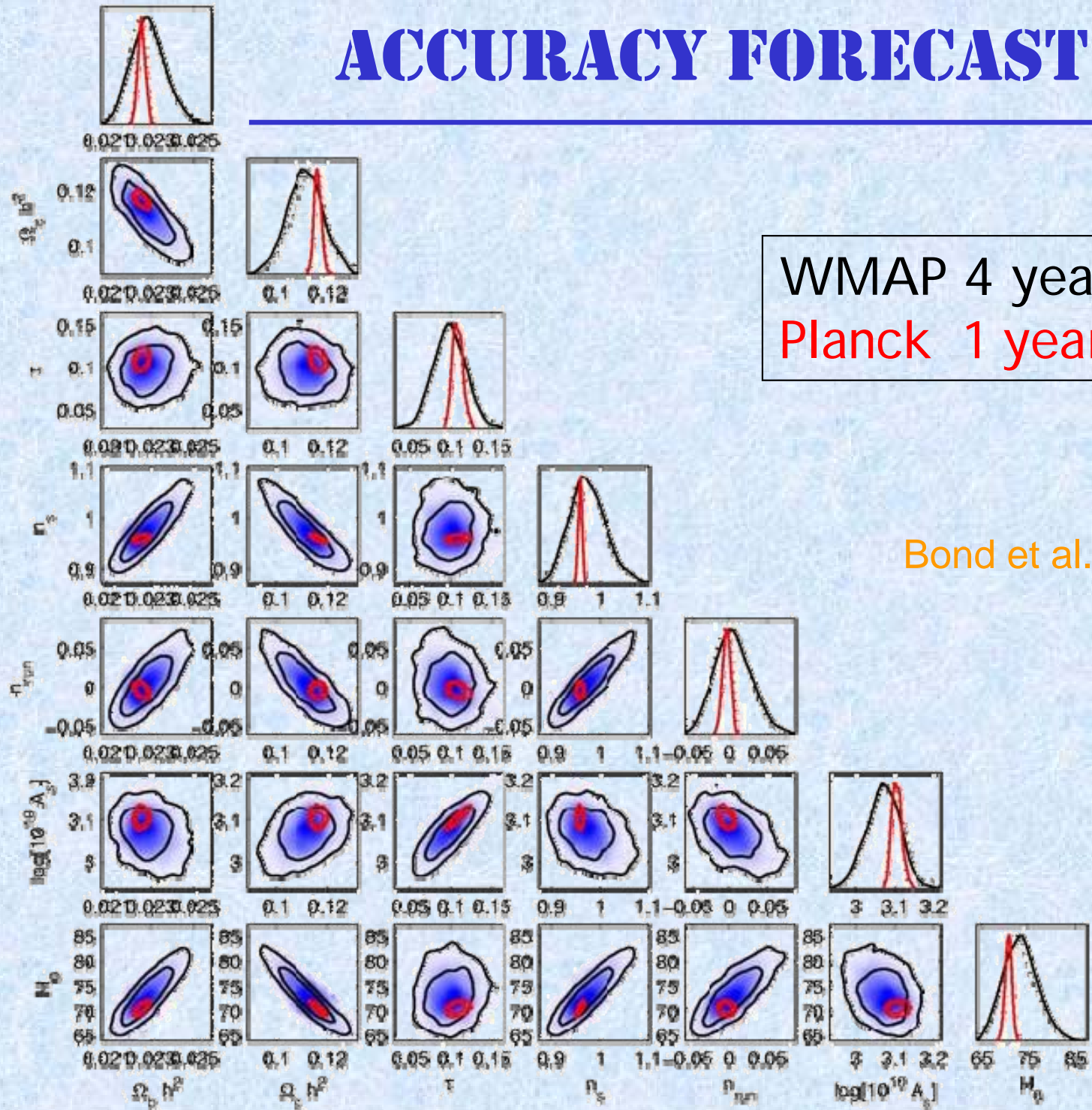

WMAP 4 years (94 GHz)
Planck 1 year (143 GHz)

Bond et al. [astro-ph/0406195](http://arxiv.org/abs/astro-ph/0406195)



REIONISATION

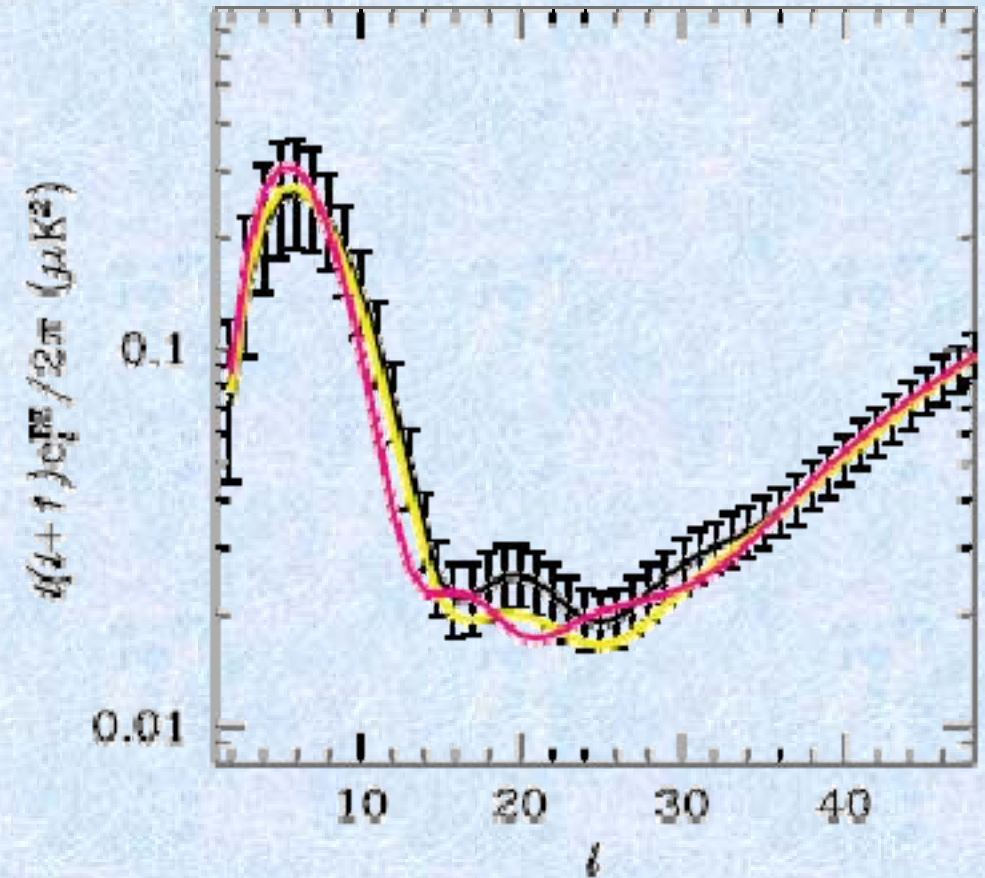
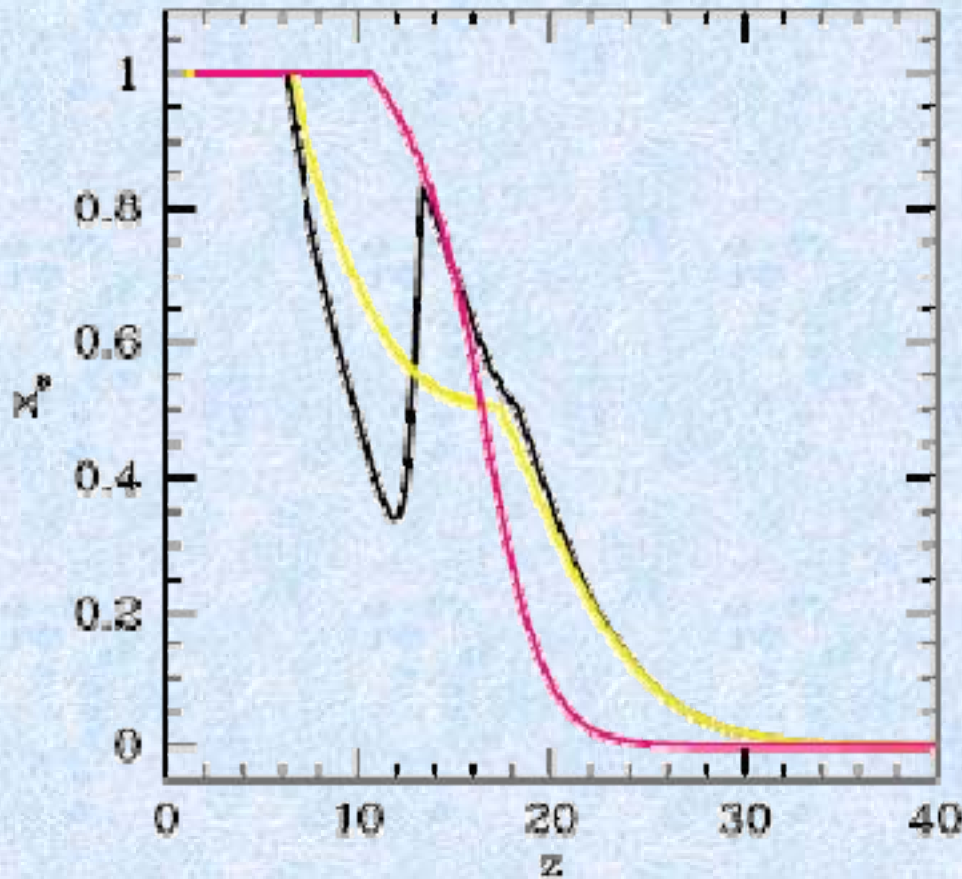

- Different reionisation histories leave a slightly different imprint (in low- l polarisation bump) which **can** be detected ...

WHAT'S NEXT?



- ✚ Planck-HFI FM is right now at IAS in Orsay, cooling down in Saturne tank...
- ✚ To be delivered this summer to ALCATEL.
- ✚ Then CSL system level tests
- ✚ **Current launch date is ~ early 2008**

- ✚ Then 4 month to go to L2
- ✚ 2 month of PV phase (> survey starts ~ Sep 2008)
- ✚ 1 year nominal operation
- ✚ 1 year Data analysis
- ✚ 1 year proprietary > Public data deliveries ~ end of 2010

- ✚ Another year of operations might be doable (to keep Planck DPC team of IAP busy longer...some started ~1993)

CMIBPOL

SAMPAN



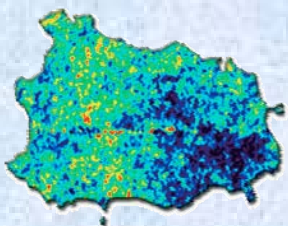

PLANCK & THE B MODES

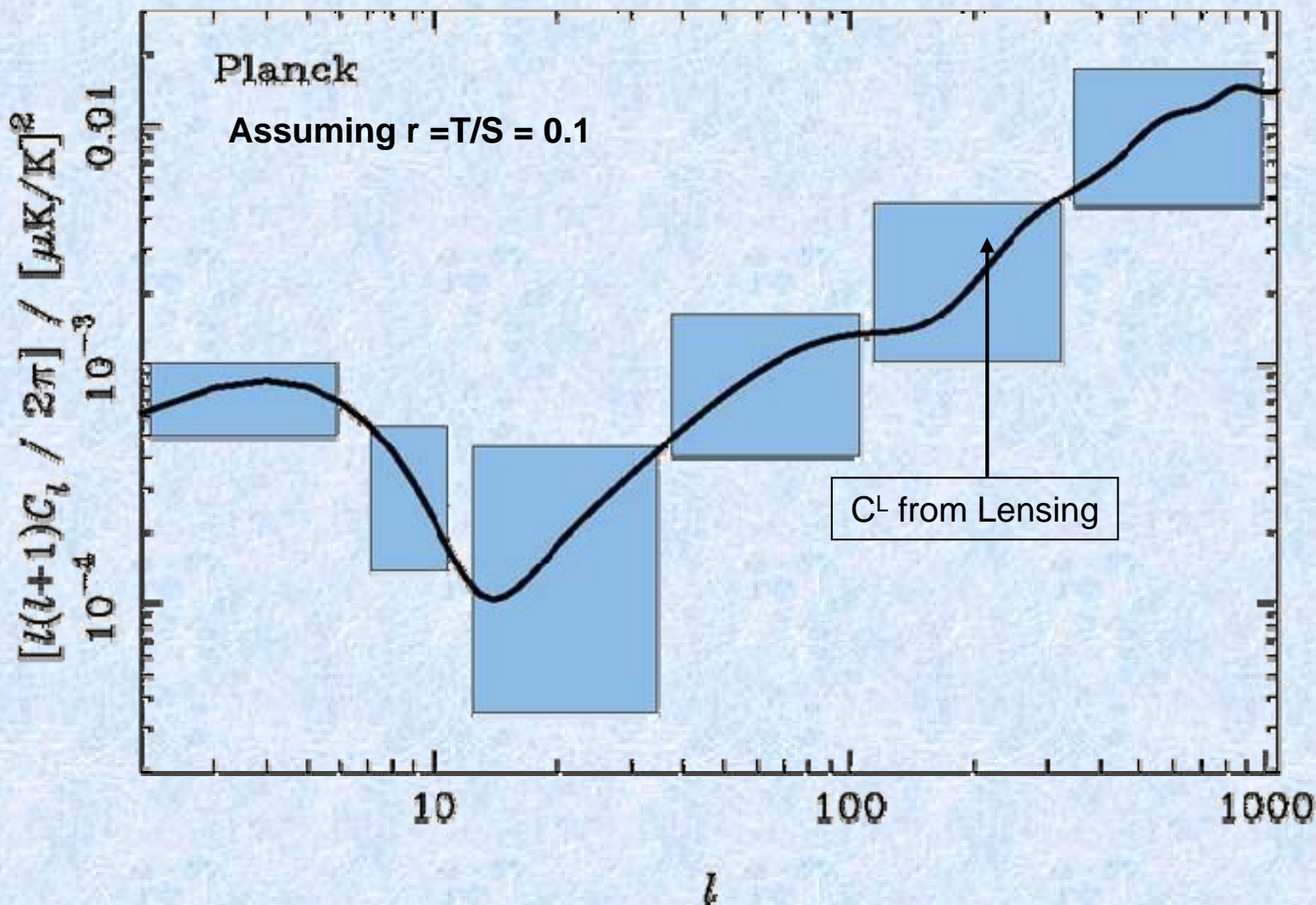

Planck will be limited by its (polarisation) sensitivity (~60 μ K.arcmin at best)

Indeed, it was conceived to be limited by unpolarised foregrounds confusion

GENERIC INFLATION

What is the value of $r = T/S$?

Take a few simple monomial potentials (quadratic, cubic, quartic), count unnecessary features introduced during 60-e fold of inflation to get a particular (n_s, r)
(ie measure number of derivatives of slow-roll parameters to adjust)

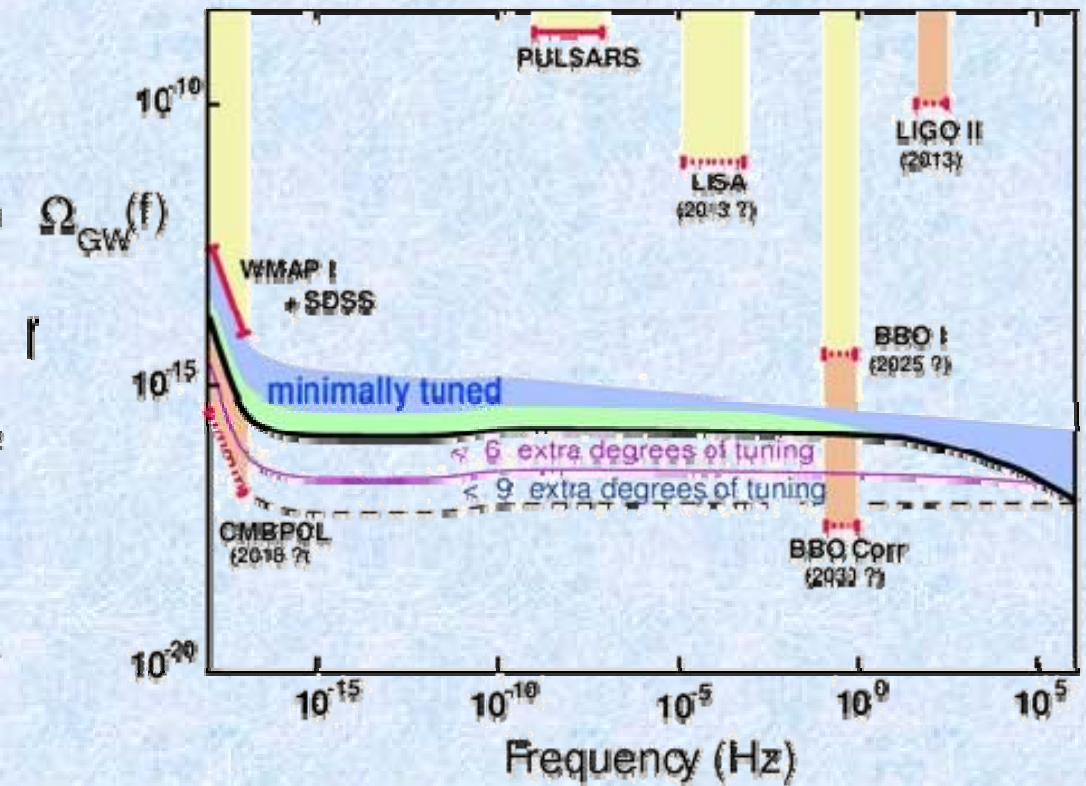
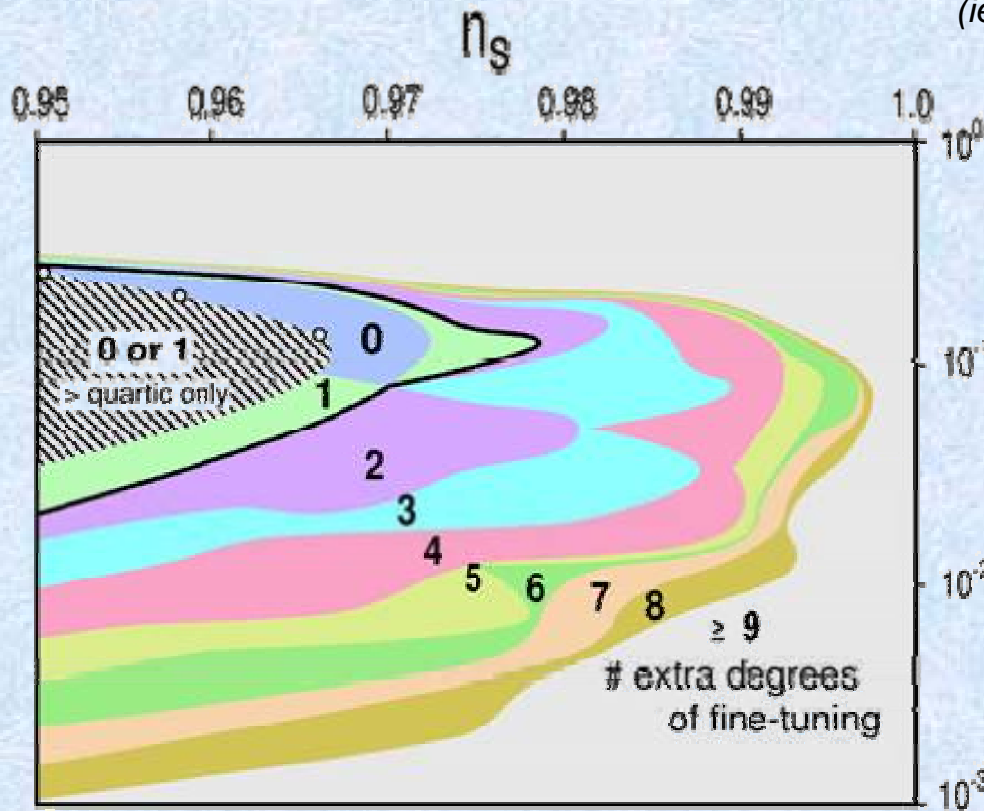

$r=T/S < 10^{-3}$ would be rather unnatural

But of course no real measure on "theory space"

Boyle, Steinhardt, Turok - astro-ph/0507455

LENS “CLEANING” EFFICIENCY

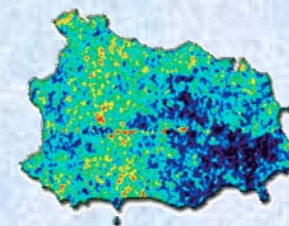

By using quadratic estimators of displacement field

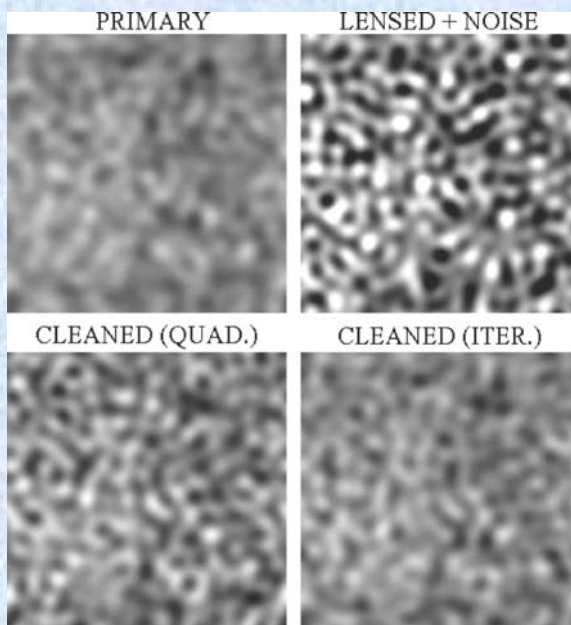

Seljak & Hirata astro-ph/0310163

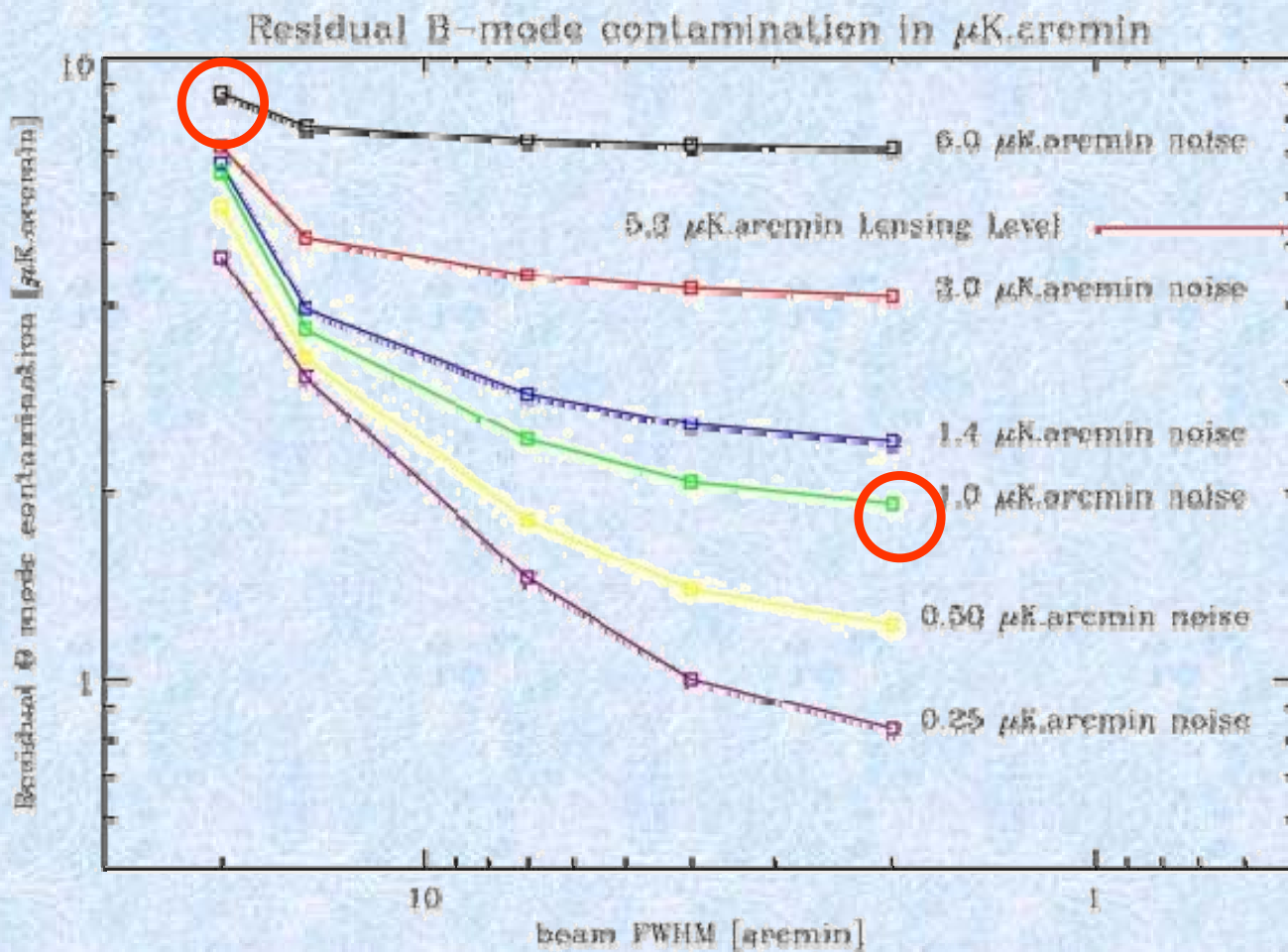

2 possible bounding cases:

■ SAMPAN: 5 $\mu\text{K}\cdot\text{arcmin}$ & 20 arcmin FWHM (i.e. no cleaning)

■ CMBPOL : 1 $\mu\text{K}\cdot\text{arcmin}$ & 2 arcmin FWHM (lots of further science at high res)

CMB AS A WEAK LENSING EXPERIMENT

✚ plotted is the deduced convergence power spectrum (related to the integrated mass responsible for lensing) in the ambitious case

✚ Interest:

- Source redshift is known (recombination)
- Linear power spectrum - (easy calculations)
- Test growth rate of structures accurately
- Check precisely the consistency of the paradigm

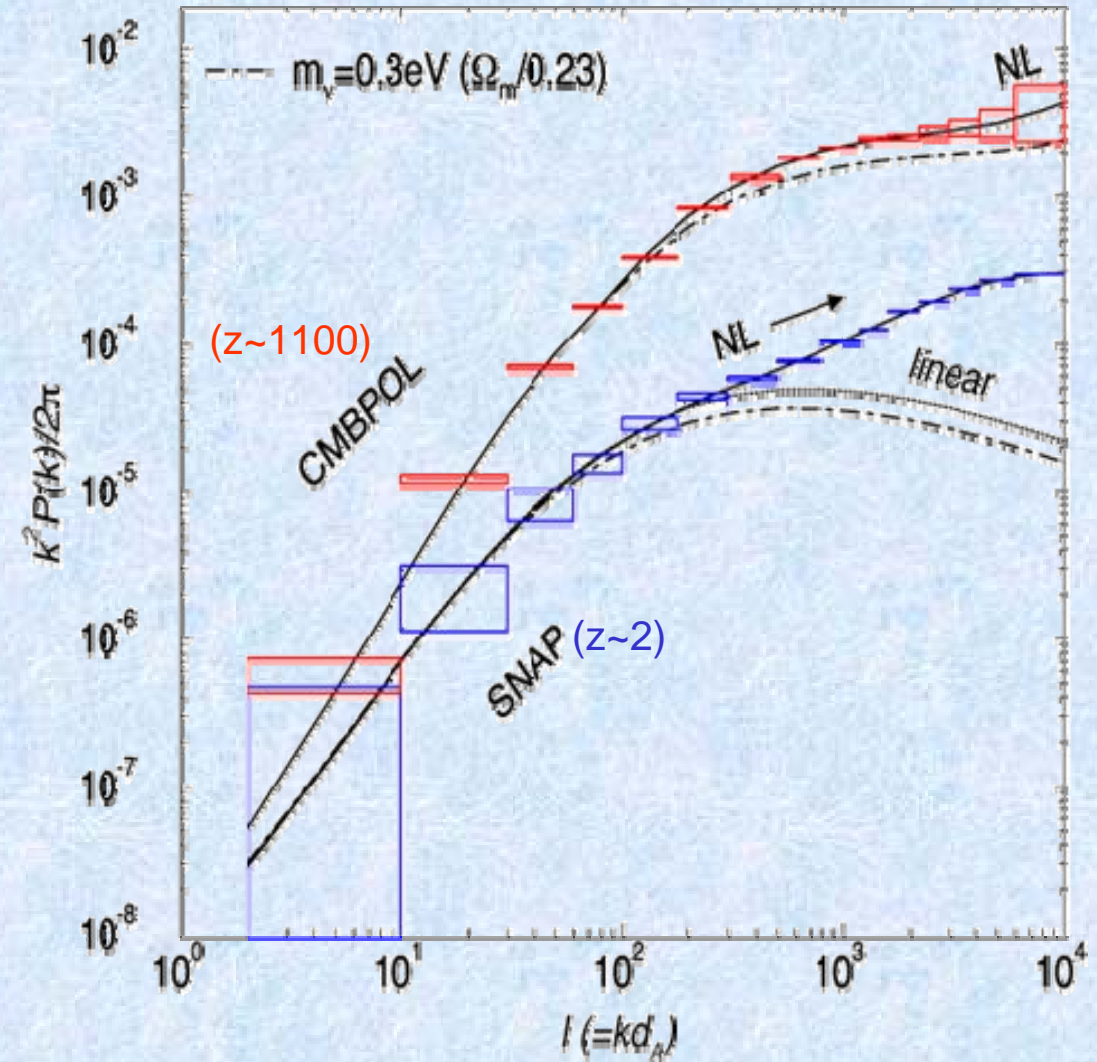

MEASUREMENTS IN PERSPECTIVE

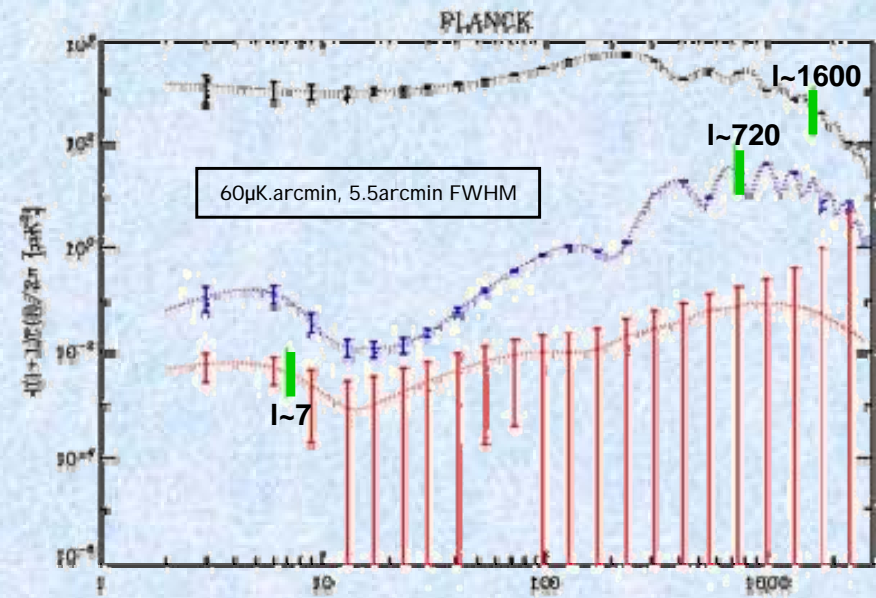
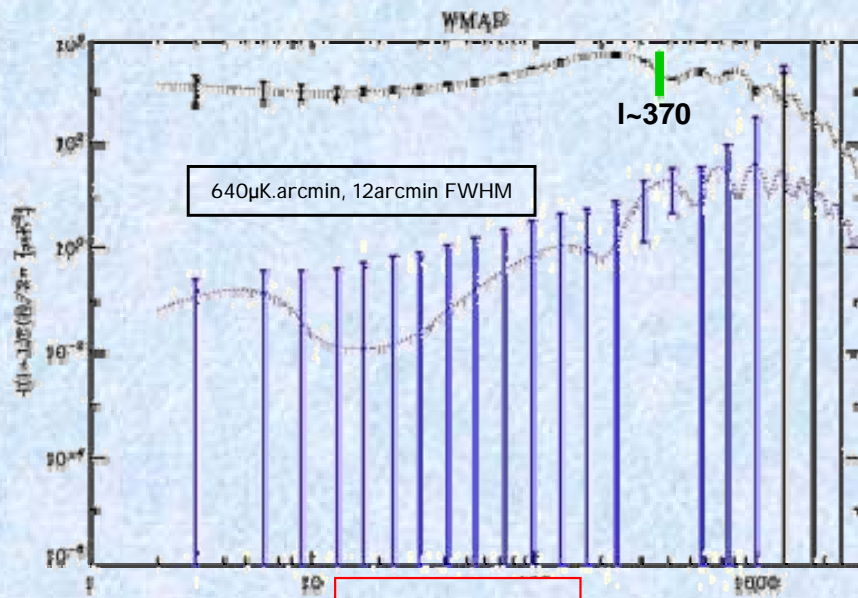

SAMPAN

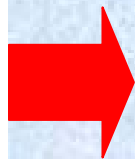
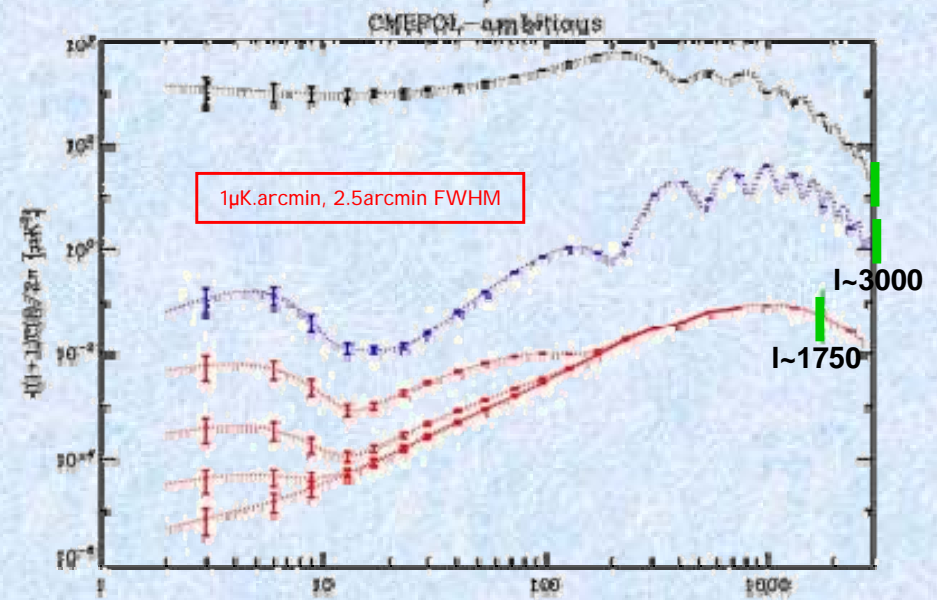
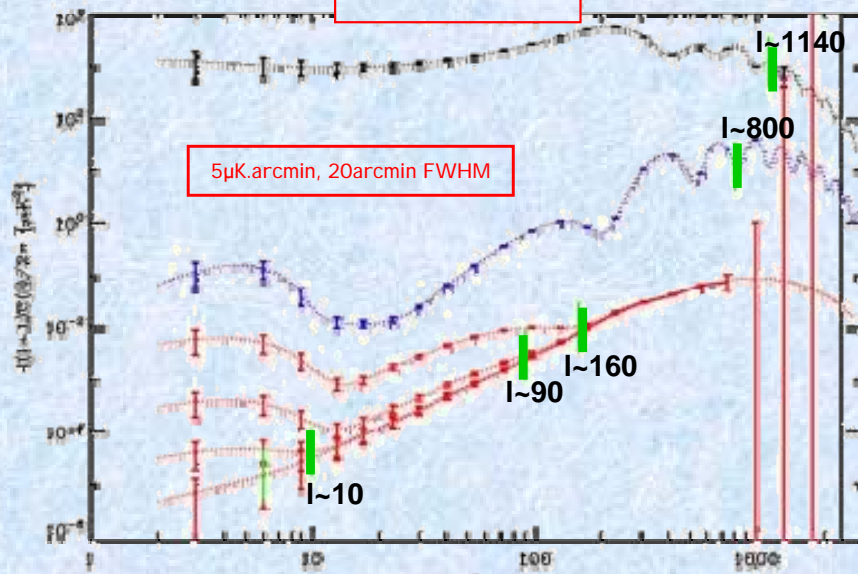

l bounds region (at left) with modes measured @ S/N > 1



CONCLUSIONS

- + From Hinshaw :
 - + WMAP three-year data includes full-sky polarization maps
 - + Analysis of EE + BB power spectra
 - + Improved measurements of many degenerate parameter pairs, especially (τ , n_s)
 - + New limits on dark energy eq. of state, flatness.
 - + Spacecraft continues to function well.
-
- + NB: many indications of non-gaussianity and/or anisotropies at large scale. Much work, but nothing has changed much after yet (large scales are already well known)

CONCLUSIONS (1/2)

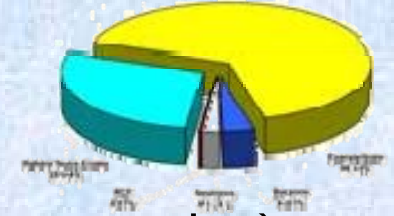

- + La cosmologie dispose d'un modèle minimal, cohérent, robuste, surprenant, à 6 (7) paramètres (concordance).
- + Le RCF fournit les tests cosmologiques les plus précis; mais d'autres méthodes (e.g. SDSS, SN-I a...) sont essentielles pour lever certaines dégénérescences.
- + Un grand nombre d'"extensions" du modèle minimal, et la plupart de modèles d'inflation, sont encore possibles ou peu contraints aujourd'hui...
- + Planck va fournir la mesure définitive des anisotropies de température, une mesure précise de la partie E de la polarisation et une première analyse de la partie B (grâce aux PSBs). Planck va ouvrir une nouvelle fenêtre sur la physique de l'Univers primitif.
- + Un satellite post-Planck (au moins 10 fois plus sensible) est à l'étude partout dans le monde pour caractériser le fond d'onde gravitationnel primordial.
- + Beaucoup d'opportunité de trouver des failles de notre compréhension

- + NB: En dépit de ces grands progrès, nous ne connaissons pas la nature de la matière sombre, ni celle de l'énergie sombre !
- + Les difficultés rencontrés (eg formation galaxies) indiquent-elles les limites de notre compréhension « gastrophysique », demande des propriétés plus complexes de DM et/ou DE, ou constituent t elle les premières traces d'une nouvelle physique?